

---

# Investigating Potential Alignments between Modelica Standard Library and SAREF Ontologies

---

Ana Roxin, [ana-maria.roxin@ubfc.fr](mailto:ana-maria.roxin@ubfc.fr)

*Laboratoire d'Informatique de Bourgogne (LIB), Univ. Bourgogne Franche-Comté (UBFC), Dijon, France*

Vishak Dudhee, [v.dudhee@tees.ac.uk](mailto:v.dudhee@tees.ac.uk)

*School of Computing, Engineering and Digital Technologies, Teesside University, Middlesbrough, UK*

Vladimir Vukovic, [v.vukovic@tees.ac.uk](mailto:v.vukovic@tees.ac.uk)

*School of Computing, Engineering and Digital Technologies, Teesside University, Middlesbrough, UK*

## Abstract

Simulation tools based on the Modelica language provide comprehensive modelling and simulation approaches for building energy systems. However, the simulation and optimisation of such systems are data-driven processes, lacking a common understanding of information structure within the process. This paper investigates the possible semantic alignments of the Smart Appliances REFERENCE (SAREF) ontology and its extension for building domain, SAREF4BLDG, with the Modelica Standard Library (MSL). Using the MSL, a residential heating system has been modelled in OpenModelica, an open-source modelling and simulation environment. Then, SAREF and its extension SAREF4BLDG semantic alignments to the MSL used to create the model have been assessed. A list of alignments has been proposed to expose semantic links for the residential Heating, Ventilation, and Air Conditioning (HVAC) system. Such alignments would allow for the semantic annotation of building energy system models and greater interoperability between modelling environments.

**Keywords:** Building Energy Systems, Modelica Standard Library, Ontologies, SAREF, SAREF4BLDG

## 1 Introduction

The residential sector holds the majority share of the global building stock and accounts for 22% of the global final energy consumption (UNEP, 2020). In the European Union, buildings account for 36% of CO<sub>2</sub> emissions, and their heating and cooling systems account for 50% of the EU's final energy consumption (Pohoryles et al., 2020). The building performance gap, which is the difference between the predicted and actual consumption, varies between 10-30%, whereas in some cases can reach up to 150-250% (IPEEC, 2019). Computer-based simulation can provide behavioural information of energy system models and can be used to improve physical systems' performance (Nguyen et al., 2014). Simulation tools based on the Modelica language provide a comprehensive modelling and simulation approach. However, optimising the simulated model can further enhance the system's efficiency by finding the optimum system parameters (Kashif et al., 2020; Ali et al., 2018; Ali et al., 2015(a); 2015(b); Ali et al., 2013; Fontanella et al., 2012; Haumer et al., 2012). Simulation-based optimisation is a data-driven process. Therefore, there is a need for interoperability of the tools used in such engineering practices. The interoperability of two systems can be defined as using a single method to exchange or access information (Roxin et al., 2019). A mutual interpretation of an element incorporated in a message exchange can be

defined using semantic interoperability. However, in practice, due to the heterogeneous definitions and interpretations of different systems, the implementation of interoperable methods is challenging (Alani et al., 2021).

This paper aims to reduce semantic heterogeneity by linking the Smart Appliances REFERENCE (SAREF) ontology and its extension for building domain, SAREF4BLDG, with the Modelica Standard Library (MSL). A list of alignments is created to expose semantic links of residential heating, ventilation and air-conditioning (HVAC) system models based on an example created using MSL.

## **2 Literature Review**

### **2.1 Digital Twin-Based Optimisation**

The digital twin concept allows the construction sector to move from a static and closed information environment to a dynamic and web-based environment with a constant flow of information (Boje et al., 2020). Digital twin-based optimisation in building energy systems contains computer-based numerical simulations of mathematically modelled systems, enriched with real-time parameters and algebraic optimisation. Computer-based simulation can provide behavioural information of the energy system's model and subsequently enhance the physical system's performance. When seeking to find an optimal solution for the simulated model, an iteration-based approach is mainly adopted. With such an approach, each iteration moves the solution closer to the optimum solution (Evins, 2013; Wetter, 2016). Using the optimisation process, the optimum input can be discovered. Optimisation-based methods generally encompass the coupling of building simulation and optimisation software that uses optimisation algorithms (Machairas et al., 2014; Li et al., 2017). The simulation-based optimisation techniques can be used to design high-performance building energy systems. In the building's operational phase, disparities between predicted and measured performance can be reduced through an optimisation-based calibration process (Reddy et al., 2007; Coakley et al., 2014; Fabrizio & Monetti, 2015). In the calibration process, the simulation input is finetuned so that the measured energy consumption of an energy system matches the one predicted by the simulation software. Optimisation-based calibrations have shown their potential to precisely simulate the operation of building energy systems with a cumulative percentage error accuracy of around 1% over a six-month process (Kashif et al., 2020; Ali et al., 2018; Fontanella et al., 2012). The use of energy systems calibration is increasing in retrofitting existing buildings and commissioning new buildings to predict their energy demand more accurately.

### **2.2 Modelica**

#### **2.2.1 Programming Language**

Modelica is a modelling language that facilitates designing physical systems behaviour (Modelica Association, 2021). The Modelica language provides a comprehensive modelling and simulation approach. Differential, algebraic, and discrete equations mathematically describe models in Modelica. The object-oriented nature of the Modelica language allows equation-based modelling of complex physical systems. It is a multi-domain language; therefore, its usage is not limited to a specific sector or area of use. Several Modelica-based simulation tools exist and are used for industrial product design, research, and teaching. The language supports proper library development of simulation models and allows exchanging them to reuse established modelling knowledge. In the Modelica language, classes are extensible program-code templates that provide the structure of objects or instances to create objects (Fritzson, 2014). Each object can be classified as an instance of a class, and several objects can be regarded as composite objects, consisting of instances of other classes. Classes can contain equations and executable codes based on the equations. Interactions between different classes are established using connectors.

In Modelica, a modelled class is termed as a simulation model, and other classes can be described as a flat Modelica structure defining functions, packages, and partial models. The function can be used to provide algorithmic contents; the packages can be used as a structuring mechanism; and the partial models are base-models. The flat Modelica structure allows for the verification of the

classes' correctness before utilising them to create the simulation models. Modelica allows symbolic transformation of models to map any Modelica language to form continuous or instantaneous equations in the flat Modelica structure.

### 2.2.2 Modelica Standard Library

The Modelica Standard Library (MSL) provides multi-domain models based on standardised interface definitions (Modelica Association, 2020). The MSL called 'Package Modelica' is a free library created and maintained by the Modelica Association. The MSL is released under the Modelica License 2, which allows both open source and commercial usage, copying, and modification of models. The MSL provides multi-domain models and standard model interfaces such as electrical, electronic, magnetic, mechanical, fluid, and control systems. The MSL also has a library of mathematical and utility functions for scripting. The Modelica library is only compatible with Modelica-based simulation environments such as OpenModelica, Dymola, Simplorer, and MapleSim.

## 2.3 Modelling with ontologies

### 2.3.1 Overview

An ontology is a formal and explicit specification of a shared conceptualisation of a knowledge domain (Studer et al., 1998). Ontologies' formal semantics are built upon Resource Description Framework (RDF) oriented graph model structure. According to RDF, statements are defined using triples—meaning two nodes, the Subject and the Object—connected by a directed arc, namely the Predicate. The Subject, Predicate, and Object are defined not by their name (or label) but through a unique Web identifier, namely a Uniform Resource Identifier (URI). The Subject of a statement can be the Object of another one and vice versa. Thus, put together, such statements form vocabularies or ontologies, represented as directed graphs. Ontologies are defined using ontology languages, which differ in their expressivity level, such as the logical constructs they allow. Namely, the Web Ontology Language (OWL) family is more expressive than RDF Schema (RDFS) because it allows more logical constructs from Description Logics (DL). Ontologies contain a so-called Terminological Box (TBox) composed of definitions of classes and properties, along with an Assertional Box (ABox) comprising instances of the classes and properties from the TBox. A knowledge base contains a TBox and an ABox. In the rest of this paper, we treat the terms "ontology" and "knowledge base" as synonyms. A knowledge base thus contains facts about a knowledge domain, specified as logical primitives. Being formal and explicit, such specification allows the execution of decision algorithms or reasoners. A reasoner allows materialising implicit facts from the explicit ones in the knowledge base.

The formalisms behind ontologies are different than the ones behind the Modelica Programming Language. In ontology development, an instance must respect an ensemble of logical conditions (Noy & McGuinness, 2001). One possibility is to specify necessary conditions: in this case, if an instance belongs to a class, then it must respect such necessary conditions. Still, one cannot infer that an instance respecting the necessary conditions belongs to the related class, namely because the conditions are not sufficient. Another possibility is to define necessary and sufficient conditions. If an instance respects this ensemble of conditions, it is automatically inferred that it belongs to the related class. Conditions are expressed through properties and restrictions on these properties, qualified or not. The expressivity level of the ontology language limits the type of logical constructs used in forming conditions. The more expressive an ontology is, the more time it takes a reasoner to materialise inferences. OWL comes as a family of languages, providing several language profiles with different expressivity levels to maximise reasoning efficiencies, such as OWL 1 (Dean et al., 2004) and OWL 2 (Motik et al., 2012) families.

Two main other assumptions apply in ontology engineering: a) the non-unique naming assumption (NNA) and b) the Open World assumption (OWA). The NNA states that it is not because two elements bear the same name or label that they must be assumed identical. In ontology engineering and in Semantic Web, two elements are only inferred identical if they hold the same URIs as identifiers. The OWA states that it is not because some information has not been defined or specified that it must be assumed to be false. For example, suppose an ontology holds a statement that Building A is located near Building B. In that case, it cannot be inferred that

Building A is not located near Building C. Indeed, this might be the fact, but it just has not been specified in the ontology. Thus, with OWA holding, one must explicitly define what may not exist or what must not be inferred as true. Another consequence of OWA is that a class is not inferred as the union of its subclasses (which is the case in the other modelling approaches, such as the unified modelling language (UML)).

### 2.3.2 SAREF Ontology

The Smart Appliances REference (SAREF) ontology is a shared consensus model which allows the pairing of existing smart appliances (Daniele et al., 2016). The first version of the SAREF ontology was released in 2015 by the SmartM2M ETSI Technical Committee, and SAREF is now an ETSI standard (ETSI, 2017). SAREF focuses on the concept of Device, which is defined as “a tangible object designed to accomplish a particular task in households, common public buildings, or offices” (Daniele et al., 2015). The SAREF ontology consists of a list of basic functions exposed as properties that can be merged to provide much more complex functions in a single device. A service offered by a device is the representation of a function to a system. As a service is exposed through some ledger, such function can be discovered, registered, and remotely controlled by other devices within the considered system. SAREF also considers the concept of Device, being characterised by an energy or power profile, that can be used to optimise the energy efficiency in a residential or commercial building. Using terms from the SAREF ontology to annotate existing data allows reaching semantic interoperability in applications centred on digital assets. Further extensions of SAREF are now undertaken in the context of the ETSI Specialist Task Force 578 (ETSI, 2019).

### 2.3.3 SAREF4BLDG

SAREF4BLDG is an extension of the SAREF ontology for building domain (Poveda-Villalón & Garcia-Castro, 2020). It was created based on the Industry Foundation Classes (IFC) standard for building information (ETSI, 2020). A section of the IFC standard (ISO 16739:2013) focusing mainly on building professionals and the different phases of a building lifecycle has been integrated into SAREF4BLDG. The SAREF4BLDG ontology further extends the interoperability allowed by SAREF to encompass various stakeholders from the building domain, such as architects, engineers, contractors, and manufacturers. SAREF4BLDG is designed to allow seamless communication of buildings' appliances that supports the IFC data model and exchange neutral device description. SAREF4BLDG is an OWL-DL ontology that is an extension of the core SAREF ontology to include and represent building appliances defined in IFC.

## 3 Methods

To investigate the possible alignments between MSL and SAREF ontologies, a residential heating system was selected for analysis. In the EU residential sector, heating systems have the most critical end-use, and they are major energy consumers. Therefore, we selected this case to investigate potential alignments.

### 3.1 Residential Heating System

The heating system of a room was modelled in the OpenModelica environment. OpenModelica is an open-source Modelica language-based platform for modelling, compiling, simulating, and analysing complex dynamic systems (Fritzson, 2011). The software is continuously being developed by the Open Source Modelica Consortium, a non-profit organisation. OpenModelica usage is intended for both academia and industry to promote research, teaching, and industrial developments. Currently, the software can be applied to various sectors, such as automotive, buildings, and power generation. Within the OpenModelica environment, the OpenModelica Connection Editor (OMEdit) is a graphical user interface that allows creating, browsing, editing, and simulating models. To use the OMEdit, the user does not need to have any prior knowledge of coding or special commands, making OpenModelica an inclusive simulation environment for both technical and non-technical users.

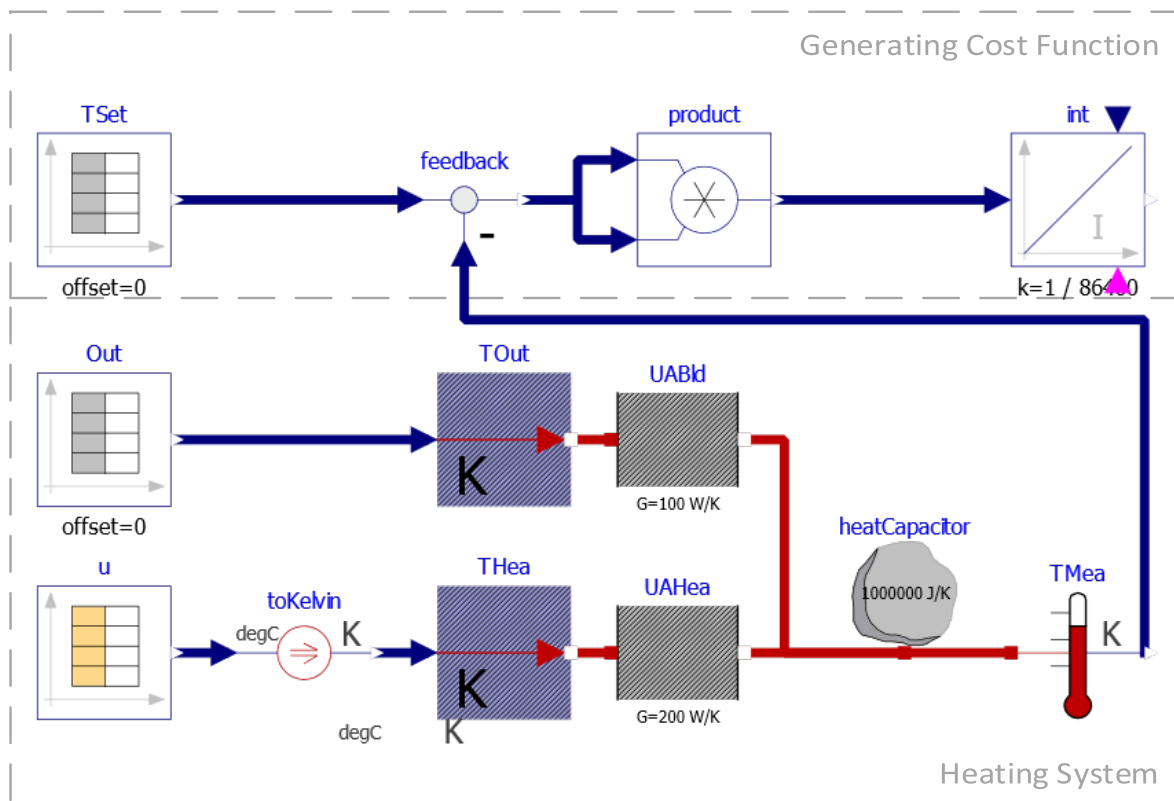

Figure 1. Residential heating system developed in OpenModelica

The heating system illustrated in Figure 1 was developed using components from the MSL 3.2.3. The room is simplified as a heat capacitor and is set to capacity  $C = 1000000 \text{ J/K}$ . The capacitor is connected to two heat sources representing the outdoor heat and the indoor heat (from the heating system). The outdoor temperature and the heating system setpoints are controlled by a parameter prescribed in a combi table *Out* and *u*. The capacitor is connected to a sensor to measure the room temperature and send the readings to the feedback component, which calculates the difference between commanded and feedback inputs. The feedback component is also connected to the TimeTable, which describes the predicted temperature. The feedback component's output is then sent to the product and integrator components used to calculate the objective function value, which is the sum squared error between the simulated and monitored values. As annotated in Figure 1, the model is in two portions: (1) the heating system components and (2) the components that calculate the objective function of the model that needs to be minimised.

### 3.2 Modelica Libraries

Following the description in Section 3.1, we can specify the related knowledge through an ontology. Such ontology comprises a list of classes along with object properties and datatype properties. These are listed in Tables 1-3, along with their references. Figure 2 provides an overall view of the considered terminology extracted from Figure 1. Figure 2 presents a portion of the Modelica taxonomy. All blocks are of type (rdf:type) `rdfs:Class` and all links must be interpreted as `rdfs:subClassOf` relations.

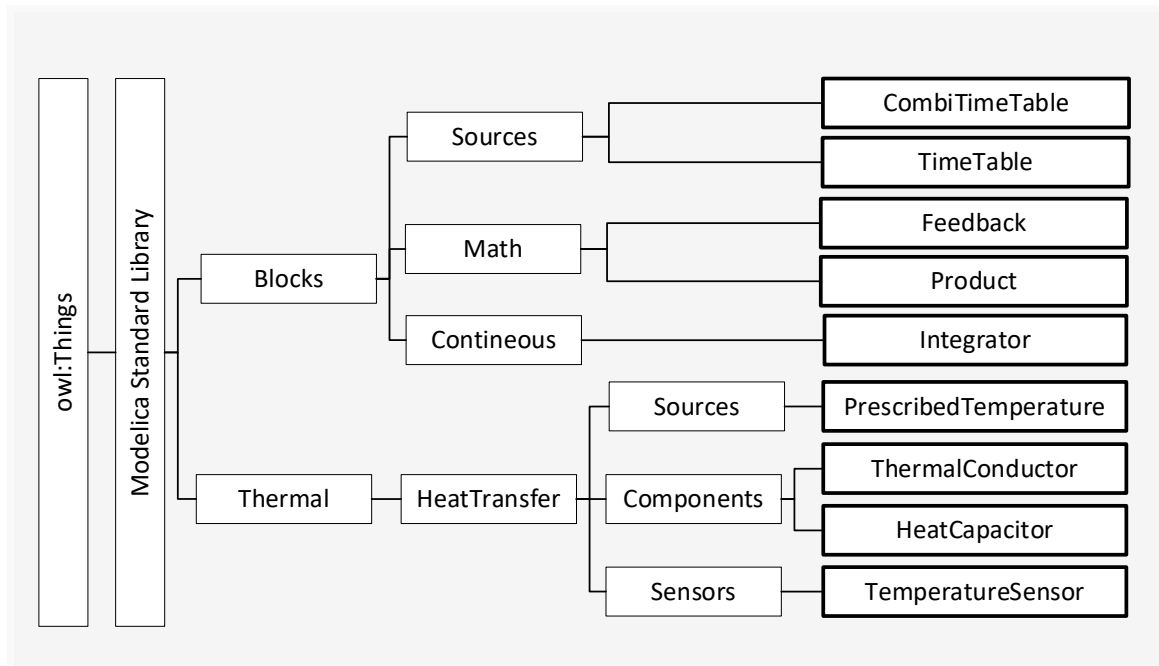

Figure 2. Residential heating system components (extract of the Modelica taxonomy)

Several of the above terms have the same name or label, although they do not refer to the same concepts. Sources for Block elements differ from Sources for Thermal elements. Moreover, several of the above-listed terms recall concepts already defined in several existing ontologies, some of the standards such as SAREF. Thus, to ease the integration of information from systems modelled using OpenModelica, the next section will investigate potential alignments between terms from the MSL and concepts from SAREF and its SAREF4BLDG extension.

#### 4 Linking MSL terms with SAREF and SAREF4BLDG

Before specifying any alignments, we provide the exact definitions of the terms listed in Figure 2 above. We do this to ensure a clear interpretation of these terms, and it is based on these definitions that the alignments proposed below should be considered. These definitions are provided in Table 1. We also provide the definitions for the SAREF and SAREF4BLDG concepts considered in our alignments (see Table 2). Finally, the alignments are listed in Table 3. The alignments defined also suppose that terms extracted from the MSL are modelled as concepts of a Modelica taxonomy - every term listed in the first column of Table 2 must be interpreted as a subclass of owl:Thing. The specification of the overall Modelica taxonomy represents ongoing work and is further discussed in Section 5. Additionally, rdfs:subClassOf relations must be assumed among terms and their sub-terms. For example, a HeatCapacitator is a sub-class of Components (itself being a subclass of owl:Thing).

Table 1. Definition of the concepts from Figure 2

Concept	Definition
<b>Blocks</b>	Library of basic input/output control blocks: continuous, discrete, logical and table blocks
<b>Continuous</b>	Library of continuous control blocks with internal states
<b>Integrator</b>	Outputs the integral of the input signal with optional reset
<b>Math</b>	Library of Real mathematical functions as input/output blocks
<b>Feedback</b>	Output difference between commanded and feedback input
<b>Product</b>	Output product of the two inputs

<b>Sources</b>	Library of signal source blocks generating real, integer and Boolean signals
<b>CombiTimeTable</b>	Table look-up with respect to time and linear/periodic extrapolation methods (data from matrix/file)
<b>TimeTable</b>	Generates a signal by linear interpolation in a table
<b>Thermal</b>	Library of thermal system components to model heat transfer and simple thermo-fluid pipe flow
<b>HeatTransfer</b>	Library of thermal system components to model heat transfer and simple thermo-fluid pipe flow
<b>Components</b>	Lumped thermal components
<b>HeatCapacitor</b>	Lumped thermal element storing heat
<b>ThermalConductor</b>	Lumped thermal element transporting heat without storing it
<b>Sensors</b>	Thermal (temperature and heat flow) sensors
<b>TemperatureSensor</b>	Absolute temperature sensor in Kelvin
<b>Sources</b>	Thermal (temperature and heat flow) sources and conditions
<b>PrescribedTemperature</b>	Variable temperature boundary condition in Kelvin

We can note that Figure 1 also implicitly defines relations or properties among these elements. Still, it is beyond the scope of this paper to explicitly define such properties. Thus, terms related to such implicit properties will not be considered in the alignments proposed below (e.g. the measurement done by a TemperatureSensor). Section 5 includes complementary details about the ways Modelica relations could be annotated with properties from existing ontologies.

Additionally, other terms listed in Table 1 are not aligned with SAREF and its extensions. This is mainly because such terms have a meaning too complex that it cannot be mapped to an existing concept, but would imply defining a more complex restriction among concepts and properties. For example, this is the case for CombiTimeTable, and all the terms related to Blocks, e.g., Continuous and Math terms and related sub-terms. Continuous and Math terms refer to elements needed in Modelica to calculate an objective function, and thus they do not represent real components of a heating system.

**Table 2.** Proposed alignments between the Modelica Standard Library and SAREF4BLDG concepts

<b>Modelica concept</b>	<b>Predicate</b>	<b>SAREF4BLDG<sup>1</sup></b>
<b>(Sources)TimeTable</b>	skos:narrower	s4ehaw:TimeSeriesMeasurement
<b>Thermal</b>	rdfs:subClassof	s4bldg:DistributionDevice
<b>HeatTransfer</b>	rdfs:subClassOf	s4bldg:HeatExchanger
<b>Component</b>	rdfs:subClassOf	s4bldg:HeatExchanger
<b>HeatCapacitor</b>	rdfs:subClassOf	s4bldg:HeatExchanger
<b>(Thermal)Sensors</b>	rdfs:subClassOf	s4bldg:Sensor, saref:Sensor
<b>TemperatureSensor</b>	owl:equivalentConcept	saref:TemperatureSensor

It can be noted from the table above that only a few terms from the MSL have a clear semantic link towards a concept in SAREF and its SAREF4BLDG extension. Only the TemperatureSensor concept has an equivalency towards saref:TemperatureSensor. All other terms can barely be defined as sub-classes of existing SAREF classes. Given the specificities of the Modelica Standard Library (see terms' definitions provided in Table 1), lighter alignments using predicates from the SKOS - Simple Knowledge Organisation System (WC3, 2009) vocabulary could be considered along with the other extensions of SAREF. For example, (Sources)TimeTable appears as a narrower concept than s4ehaw:TimeSeriesMeasurement.

<sup>1</sup> The corresponding namespaces are:  
s4bldg: <https://w3id.org/def/saref4bldg#>  
saref: <https://w3id.org/saref#>  
s4ehaw: <https://saref.etsi.org/saref4ehaw/>

**Table 3.** SAREF and SAREF4BLDG concepts' definition (according to the ETSI specification<sup>2</sup>)

Classes	Definition
<b>s4bldg:DistributionDevice</b>	The generalisation of all devices that participate in a distribution system
<b>s4bldg:HeatExchanger</b>	A heat exchanger is a device used to provide heat transfer between non-mixing media such as plate and shell and tube heat exchangers.
<b>s4bldg:Sensor</b>	A device that measures a physical quantity and converts it into a signal.
<b>s4ehaw:TimeSeriesMeasurement</b>	A sequence of data in a successive equally spaced points in time.
<b>saref:Sensor</b>	A device that detects and responds to events or changes in the physical environment such as temperature of category saref:Sensor that performs a saref:SensingFunction.
<b>saref:TemperatureSensor</b>	A sensor that is used for the purpose of sensing a property of type saref:Temperature. A saref:TemperatureSensor is typically used to saref:accomplish saref:Comfort.

## 5 Discussion

As mentioned earlier in the article, the work presented here assumes the Modelica taxonomy, which organises into classes and sub-classes the various terms defined in the Modelica Standard Library. Based on the heating system illustrated in Figure 1 and modelled with Modelica, we tried to identify alignments to concepts from SAREF and SAREF4BLDG. Still, we noted that this could not be done in a straightforward manner, as the SAREF ontology and its related extensions follow different modelling assumptions compared to the MSL.

A first remark addresses terms from the MSL that could appear related to SAREF concepts but according to their definition (thus intended meaning) should be mapped as SAREF properties. For example, this is the case for the ThermalConductor term from MSL ("Lumped thermal element transporting heat without storing it"). Following its definition, this appears related to s4bldg:heatTransferMedium ("enumeration defining the heat transfer medium if applicable"). Still, ThermalConductor is defined as a subclass of owl:Thing (thus an rdfs:Class) cannot be related to a datatype property (owl:DatatypeProperty). Even a lighter alignment such as skos:related would entail both the subject and the object of the triple belong to skos:Concept, which is not the case.

A second remark can be made regarding the links or connections among entities in Figure 1. In Modelica, the connection between the different entities is made using only a connect command. The semantics behind such a connection must be further specified by performing a thorough analysis of every case modelled with the MSL. Several extensions of SAREF provide properties that appear pertaining to annotate such connections. We may cite s4envi:isConnectedTo<sup>3</sup> or s4syst:connectedTo<sup>4</sup>. Still, these properties have similar definitions but are not defined as equivalent nor related to one another in SAREF. s4envi:isConnectedTo is defined as "a relation between a system and the system to which it is connected", while s4syst:connectedTo is defined as "links a system to a system it is connected to". To tackle this, the MSL entities can be further characterised using restrictions built using SAREF properties. For example, a (MSL)Product should have some s4bldg:thermalMassHeatCapacity. The values expected as inputs and outputs

<sup>2</sup> Available on: SAREF (<https://saref.etsi.org/core/>), SAREF4BLDG (<https://saref.etsi.org/saref4bldg/>) and S4EHAW (<https://saref.etsi.org/saref4ehaw/>)

<sup>3</sup> s4envi: <https://saref.etsi.org/saref4envi/>

<sup>4</sup> s4syst: <https://saref.etsi.org/saref4syst/>



from the different MSL entities can also be annotated using `saref:Measurement` and related properties, namely those that have `saref:Measurement` in their domain (`saref:isMeasuredIn` or `saref:isMeasurementOf`) or in their range (`saref:hasMeasurement` or `saref:hasSensingRange`). Additionally, specific SAREF concepts could be used for defining restrictions on some measure-related properties taking into account the related units. For example `saref:Power` can be used for measurements expressed in Watts or kiloWatts, while `saref:Temperature` can be used for Celsius or Kelvin degrees.

A third remark addresses the Modelica family. The MSL is only one of the many libraries used in Modelica-based simulation environments. Other libraries such as the Buildings or BuildSysPro libraries contain more specific components to model building systems (Wetter, 2014; Plessis et al., 2014). For example, the heat capacitor used in Figure 1 to define the room's internal thermal storage could be replaced by an AirNode element from the BuildSysPro library. With precise semantic alignments (the AirNode could be aligned to `s4bldg:DistributionFlowDevice`) and restrictions, one can quantify the semantic difference between the two library components.

Finally, the idea behind this attempt to align and assess SAREF ontologies and MSL is to benefit from existing alignments to the IFC standard, as defined in S4BLDG. Through logical entailments, these can also be applied to MSL entities. Additionally, links to IFC elements missing from S4BLDG or SAREF can also be defined for MSL entities. The final goal is to annotate MSL simulation models' data with terms from other standards (such as IFC or SAREF), thus reducing semantic heterogeneity among these approaches and ensuring a seamless interpretation of the underlying data.

## 6 Conclusion

The work presented in this paper mainly focuses on the modelling of the system, with less attention being given to the simulation of the created model. A residential heating system model was created in OpenModelica using the core Modelica library, MSL. Our goal is to investigate the possible semantic alignments among the standard SAREF ontology (and its extensions) and the MSL. The preliminary findings described in this paper highlight that further research and additional specifications must be defined to link a pertaining portion of Modelica Libraries and SAREF. Some of the challenges to be addressed by future work are listed in Section 5. With all the above challenges solved, the final aim is to specify a paradigm for automatically annotating MSL entities and system data with concepts and properties from SAREF and its extensions.

While we identified some alignments among SAREF and S4BLDG concepts and MSL entities, additional ones must be defined to fully annotate a Modelica HVAC system model with SAREF and its extensions. Still, as mentioned above, such semantic annotation of systems defined with MSL allows for a seamless interpretation of the underlying data. Thus, it can help in reaching a particular optimisation of the system considered. As an extension, representing Modelica-based building energy systems for digital twins can help better interpret, and thus integrate, data uploaded by Internet of Things (IoT) devices. This appears essential for engineers and researchers in the designing of data-driven processes, such as digital twin-based optimisation of building energy systems.

## References

- Alani, Y., Dawood, N., Patacas, J., Rodriguez, S. & Dawood, H. (2021). A semantic common model for product data in the water industry. *Journal of Information Technology in Construction (ITcon)*. 26. pp. 566-590. available at: <https://doi.org/10.36680/j.itcon.2021.030>.
- Ali, M., Vukovic, V., Muhammad Ali, H. & Ahmed Sheikh, N. (2018). Performance Analysis of Solar-Assisted Desiccant Cooling System Cycles in World Climate Zones. *Journal of solar energy engineering*. 140 (4). available at: <http://dx.doi.org/10.1115/1.4039426>.
- Ali, M., Vukovic, V., Sheikh, N.A. and Ali, H.M. (2015a). Performance investigation of solid desiccant evaporative cooling system configurations in different climatic zones. *Energy conversion and management*. 97. pp. 323-339. available at: <http://dx.doi.org/10.1016/j.enconman.2015.03.025>.

- Ali, M., Vukovic, V., Sheikh, N.A., Ali, H.M. and Sahir, M.H. (2015b). Enhancement and Integration of Desiccant Evaporative Cooling System Model under Transient Operating Conditions. *Applied Thermal Engineering*. 75. pp.1093-1105. available at: <https://doi.org/10.1016/j.applthermaleng.2014.10.064>.
- Ali, M., Vukovic, V., Sahir, M.H. & Fontanella, G. (2013). Energy analysis of chilled water system configurations using simulation-based optimisation. *Energy and buildings*. 59. pp. 111-122. available at: <http://dx.doi.org/10.1016/j.enbuild.2012.12.011>.
- Boje, C., Guerriero, A., Kubicki, S. & Rezgui, Y. (2020). Towards a semantic Construction Digital Twin: Directions for future research. *Automation in construction*. 114 (103179). available at: <http://dx.doi.org/10.1016/j.autcon.2020.103179>.
- Coakley, D., Raftery, P. & Keane, M. (2014). A review of methods to match building energy simulation models to measured data. *Renewable & sustainable energy reviews*. 37. pp. 123-141. available at: <http://dx.doi.org/10.1016/j.rser.2014.05.007>.
- Daniele, L., den Hartog, F. & Roes, J. (2015). Created in Close Interaction with the Industry: The Smart Appliances REFERENCE (SAREF) Ontology. *Formal Ontologies Meet Industry*. Springer International Publishing, Cham, pp. 100-112.
- Daniele, L., den Hartog, F. & Roes, J. (2016). How to Keep a Reference Ontology Relevant to the Industry: A Case Study from the Smart Home. *Ontology Engineering* Springer International Publishing, Cham. pp. 117-123. available at: [https://doi.org/10.1007/978-3-319-33245-1\\_12](https://doi.org/10.1007/978-3-319-33245-1_12).
- Dean, M. et al. (2004). OWL Web Ontology Language Reference. *W3C Recommendation*. available at: <https://www.w3.org/TR/owl-ref/>.
- ETSI (2017). ETSI TR 103 411 - SmartM2M; Smart Appliances; SAREF extension investigation. *European Telecommunications Standards Institute*. available at: [https://www.etsi.org/deliver/etsi\\_tr/103400\\_103499/103411/01.01.01\\_60/tr\\_103411v010101p.pdf](https://www.etsi.org/deliver/etsi_tr/103400_103499/103411/01.01.01_60/tr_103411v010101p.pdf)
- ETSI (2019). Specialist Task Force 578: Specification of the SAREF development framework and workflow, and development of the Community SAREF Portal for user engagement. available at: <https://portal.etsi.org/STF/STFs/STF-HomePages/STF578> (Accessed: 06/05/2021).
- ETSI (2020). ETSI TS 103 410-3 - SmartM2M; Smart Appliances Extension to SAREF; Part 3: Building Domain. *European Telecommunications Standards Institute*. available at: [https://www.etsi.org/deliver/etsi\\_ts/103400\\_103499/10341003/01.01.02\\_60/ts\\_10341003v010102p.pdf](https://www.etsi.org/deliver/etsi_ts/103400_103499/10341003/01.01.02_60/ts_10341003v010102p.pdf).
- Evins, R. (2013). A review of computational optimisation methods applied to sustainable building design. *Renewable & sustainable energy reviews*. 22. pp. 230-245. available at: <http://dx.doi.org/10.1016/j.rser.2013.02.004>.
- Fabrizio, E. & Monetti, V. (2015). Methodologies and Advancements in the Calibration of Building Energy Models. *Energies*. 8 (4). pp. 2548-2574. available at: <https://doi.org/10.3390/en8042548>.
- Fontanella, G., Basciotti, D., Dubisch, F., Judex, F., Preisler, A., Hettfleisch, C., Vukovic, V. & Selke, T. (2012). Calibration and validation of a solar thermal system model in Modelica. *Building simulation*. 5 (3). pp. 293-300. available at: <https://doi.org/10.1007/s12273-012-0070-y>.
- Fritzson, P. (2011). Modelica — A cyber-physical modeling language and the OpenModelica environment. *7th International Wireless Communications and Mobile Computing Conference*. pp. 1648-1653. available at: <https://doi.org/10.1109/IWCMC.2011.5982782>.
- Fritzson, P. (2014). *Principles of Object-Oriented Modeling and Simulation with Modelica 3.3*. 2nd ed. Wiley. available at: <https://doi.org/10.1002/9781118989166>.
- Haumer, A., Kral, C., Vukovic, V., David, A., Hettfleisch, C. & Huzsvar, A. (2012). A Parameterisation Scheme for high Performance Thermal Models of Electric Machines using Modelica. *IFAC Proceedings Volumes*. 45(2). pp.1058-1062. available at: <https://doi.org/10.3182/20120215-3-AT-3016.00187>.
- IPEEC (2019). Building Energy Performance Gap Issues: An International Review. IPEEC Building Energy Efficiency Taskgroup.
- Kashif, A., Ali, M., Sheikh, N.A., Vukovic, V. & Shehryar, M. (2020). Experimental analysis of a solar assisted desiccant-based space heating and humidification system for cold and dry climates. *Applied thermal engineering*. 175(115371). available at: <http://dx.doi.org/10.1016/j.applthermaleng.2020.115371>.
- Li, K., Pan, L., Xue, W., Jiang, H. & Mao, H. (2017). Multi-Objective Optimisation for Energy Performance Improvement of Residential Buildings: A Comparative Study. *Energies (Basel)*. 10 (2). pp. 245. available at: <https://doi.org/10.3390/en10020245>.
- Machairas, V., Tsangrassoulis, A. & Axarli, K. (2014). Algorithms for optimisation of building design: A review. *Renewable & sustainable energy reviews*. 31, pp. 101-112. available at: <http://dx.doi.org/10.1016/j.rser.2013.11.036>.

- Modelica Association (2020). Modelica Standard Library - Version 4.0.0. Available at: <https://doc.modelica.org/Modelica%204.0.0/Resources/helpDymola/Modelica.html> (Accessed: 06/04/2021).
- Modelica Association (2021). Modelica® – A Unified Object-Oriented Language for Systems Modeling - Language Specification - Version 3.5. available at: <https://modelica.org/documents/MLS.pdf> (Accessed: 08/08/2021).
- Motik, B., Patel-Schneider, P.F. & Grau, B.C. (2012). OWL 2 Web Ontology Language Direct Semantics. 2<sup>nd</sup> Ed. W3C Recommendation. Available at: <https://www.w3.org/TR/owl2-direct-semantics/>.
- Nguyen, A., Reiter, S. & Rigo, P. (2014). A review on simulation-based optimisation methods applied to building performance analysis. *Applied energy*. 113. pp. 1043-1058. available at: <http://dx.doi.org/10.1016/j.apenergy.2013.08.061>.
- Noy, N. F. & McGuinness, D. L. (2001). Ontology development 101: A guide to creating your first ontology.
- Plessis, G., Kaemmerlen, A. & Lindsay, A. (2014). BuildSysPro: a Modelica library for modelling buildings and energy systems. *Proceedings of the 10th International Modelica Conference*. Lund University Campus, Lund; Sweden. pp. 1161-1169. available at: <http://dx.doi.org/10.3384/ecp140961161>.
- Pohoryles, D.A., Maduta, C., Bournas, D.A. & Kouris, L.A. (2020). Energy performance of existing residential buildings in Europe: A novel approach combining energy with seismic retrofitting. *Energy and buildings*. 223(110024). Available at: <http://dx.doi.org/10.1016/j.enbuild.2020.110024>.
- Poveda-Villalón, M. and Garcia-Castro, R. (2020). SAREF extension for building. available at: <https://saref.etsi.org/saref4bldg/v1.1.2/> (Accessed: 29/04/2021).
- Reddy, T.A., Maor, I. & Panjapornpon, C. (2007). Calibrating Detailed Building Energy Simulation Programs with Measured Data-Part I: General Methodology (RP-1051). *HVAC&R research*. 13 (2). pp. 221-241. available at: <https://doi.org/10.1080/10789669.2007.10390952>.
- Roxin, A. & Hbeich, E. (2019). Semantic interoperability between BIM and GIS – review of existing standards and depiction of a novel approach. In: *Proceedings of the 36th International Conference of CIB W78*. Newcastle-upon-Tyne, UK, pp. 359–369. available at: <http://itc.scix.net/paper/w78-2019-paper-035>
- Studer, R., Benjamins, V.R. & Fensel, D. (1998). Knowledge engineering: principles and methods. *Data & knowledge engineering*. 25(1). pp.161–197. available at: [https://doi.org/10.1016/S0169-023X\(97\)00056-6](https://doi.org/10.1016/S0169-023X(97)00056-6).
- UNEP (2020). 2020 Global Status Report for Buildings and Construction: Towards a Zero-emission, Efficient and Resilient Buildings and Construction Sector. United Nations Environment Programme, Nairobi
- WC3 (2009). SKOS Simple Knowledge Organization System Reference. W3C Recommendation. available at: <https://www.w3.org/TR/skos-reference/>.
- Wetter, M. (2016). *GenOpt(R), generic optimisation program, User Manual, Version 3.1.1*. Lawrence Berkeley National Laboratory - University of California. available at: <https://simulationresearch.lbl.gov/GO>.
- Wetter, M., Zuo, W., Nouidui, T.S. & Pang, X. (2014). Modelica Buildings library. *Journal of building performance simulation*. 7 (4). pp. 253-270. available at: <https://doi.org/10.1080/19401493.2013.765506>.