

---

# BIM-Driven Library for Islamic Arch

---

Ayad Almainani, ayadkh@ufl.edu

*Ph.D. Candidate, University of Florida, United States*

Nawari O. Nawari, nnawari@ufl.edu

*University of Florida, United States*

## **Abstract**

Arches are ones of the main architectural expressions in Islamic Architecture. They are distinguished by their unique styles that originate from different Islamic eras. One example of an Islamic architectural style is the Hejazi Islamic Architecture Character (HIAC), which is derived from the Ottoman Architecture Style, where arches were used as the primary symbol in building design. This paper focuses on developing BIM-driven three-dimensional components for Islamic arches including diversity, types, materials, and composition in buildings, maintaining the connection of the components to the cultural heritage and nature of Islamic Architecture. The core purpose is to present the HIAC arches library as a BIM tool that architects and engineers can utilize for restoration of Islamic historical buildings, or contemporary design projects. Furthermore, HIAC components library facilitates and provides designers with a substantial amount of data that describes arches such as era and style.

**Keywords:** BIM-driven library, Islamic Architecture, Hejazi Architecture.

## 1 Introduction

There are many papers and primary architectural references that outline the fact that arches are one of the main components of Islamic architecture (IA). Every style of Islamic architecture (IAS) is well known for particular types of architectural components that can be used to differentiate and distinguish that Islamic styles based on historical era, designs demands, plans, facades, and other architectural requirements. Every IAS is well known for using certain types of arches that are well incorporated into their architecture, structure, and construction design demands. The example applied in this paper is of the Hejazi Islamic architecture character (HIAC), which is derived from the Ottoman IA style. The Ottoman empire ruled many Arabic and non-Arabic regions of the Islamic realm which resulted in increased homogeneity that unified the Ottoman Khilafah (rulers) architectural style among the Ottoman buildings.

Grube (1987) defined IA as a set of architectural and spatial features, such as introspection, that are inherent in Islam as a cultural phenomenon. Hence, establishing a digital library of IA will assist in enabling a better understanding of IA while also providing a resourceful library for practical applications in the IA design domain. Currently, data and research efforts in digital Islamic Architecture are scarce. Examples of these research efforts comprise the work of Djibril et al., (2006) who developed a region based indexing and classification system for Islamic star pattern images using rotational symmetry information. Their classification system is based on the number of folds by which an image is characterized and the image's fundamental region and class. Okamura et al, (2007) have likewise established semantic digital resources of Islamic historical buildings focusing on Islamic architecture in Isfahan, Iran. Their research work revealed that a topic maps-based semantic model applied to collaborative metadata management paradigms can be easily exploited as a tool to enhance traditional architectural design and interdisciplinary studies. Further efforts are shown in the work conducted by Djibril et al., (2008), who examined geometrical patterns in IA and developed an indexing and classification system using discrete symmetry groups. It is a general computational model for the extraction of symmetry features of Islamic Geometrical Pattern (IGP) images. IGPs are classified into three pattern based categories. The first pattern-category describes the patterns generated by translation along one direction. The second-pattern contains translational symmetry in two independent directions. The third, which is called rosettes, describes patterns that begin at a central point and grow radially outward.

Furthermore, MA et al, (2015), conducted research focusing on the conservation traditional wooden buildings in Taiwan. They demonstrated BIM technology as an effective solution for documenting, managing, and preparing full engineering drawings and relevant information of these historic buildings.

In other recent research conducted by MA et al. (2016), they focused on some common issues that occur during the restoration and maintenance of wooden structures that represent the architectural heritage of Taiwan. These problems vary between recording the information of geometric and non-geometric objects, controlling the phases of construction, and the occurrence of structural damage during disassembly. They demonstrated a method by which BIM was used to bridge the gap in communication between designers and builders by developing a software plug-in to guide the restoration process.

The purpose sought after in this research is to complete the library of Building Information Modeling for Islamic Architecture styles (BIM-IAS) as seen in previously published researched papers. This paper focuses its efforts on Arches of Ottoman Islamic Architecture components of the Hejazi Islamic Architecture Character. As described previously, the BIM-IAS library classifies and labels architectural components chronologically based on their appearance in the IA timeline. The HIAC arches that are to be included in this library were built as parametrical three dimensional architectural and structural elements and appended with schema and data.

## 2 Methodology

### 2.1 System of Classification

The long expansion of the Ottoman Khilafah into various Islamic territories facilitated and encouraged the emergence, of an architecture style and structural entity that distinguished buildings and facilities of that era. After taking a look at different resources and research studies that examined and discussed various buildings located in different regions encompassed by Ottoman rule a group of architectural and structural arches were identified. These arches were widespread throughout regions controlled by the Ottoman Khilafah, and, over time, became an essential mainstay utilized in Ottoman architecture. This is in line with other styles and eras where unique components become an essential part of the architectural character of a particular region and era. Arches, in particular, are components that can be used in both the interior and exterior of buildings. Examples of the components sourced from various resources are outlined in Figure 1 as they are presented in the HIAC. Within the BIM-IAS each component is categorized into a character and many are unique to that character but all are considered essential components of the overall Ottoman style.

Almaimani & Nawari (2015a, 2015b, 2015, 2016) developed the general classification chart system of the BIM – Driven Islamic architecture library. They have previously published several studies associated with Hijazi Islamic Architectural Characters (HIAC) which have been aggregated and assorted into one single BIM digital library. This massive undertaking attempts to enrich the HIAC architectural, structural, and constructional elements by sorting and organizing the three dimensional elements using a hierarchical classification system. This paper aims to complete that endeavor by demonstrating how the styles included in the BIM-IA classification system can be used to create a BIM library. The focus of the research at hand is the categorization of the three dimensional HIAC components with a case study that is limited to styles that arise from the Hijaz region. In all previously published papers, especially the BIM-Driven Library for Islamic Architecture, the figures are used to describe the classification system while the Hierarchical schema of the digital classification are outlined to demonstrate the approach used in the categorization process of the BIM-IA library.

The data used to generate these figures is extracted from various Islamic Architectural references collected by the Aga Khan Program for Islamic Architecture (Islamic architecture - Aga Khan Documentation Center, 2015). Additional sources of data include: *The Coral Buildings of Suakin* by Jean-Pierre Greenlaw (1995), *The Traditional House of Jeddah: A Study of The Interaction Between Climate, Form and Living Patterns* by Sameer Al-Lyaly (1990), *Suakin: On Reviving an Ancient Red Sea Port City* by Abdel Rahim Salim (1997), and *The Development of Housing in Jeddah: Changes in Built Form The Traditional to The Modern* by Thamer Alharbi (1989).

### 2.2 Schema

When a BIM-IAS user chooses an HIAC component like the Arch, there are comprehensive charts and graphs affixed in the IAS application that are encompassed by data on the arches of the Hejaz region. There is published research called BIM-Driven Library for Islamic Architecture, this research can be used as a reference and an example, on one of the pages there is an organized table as a portion of HIAC classification for window details. Similarly, the chart embedded in the library allows the user to preview the arches' history and the AEC details. The user has various choices that ease the selection of the Arch components, such as selecting a complete individual arch (separated from any other elements), selecting a complete individual arch (identified as a part of other elements), and selecting a component part or ornamentations used to make up the arch. More than 40 arch components, provided in various forms, are included in the HIAC and have been drawn, illustrated, assembled and categorized in the BIM-IAS digital library. Each one of these three dimensional components comprises details that identify: component themes, element types, style history, character history, as well as additional architectural styles through the use of pictures and illustrations. This proposed arch library has the ability to enhance the expression of certain architectural concepts during the design phase of a project. This is supplemented by the additional information included with the components which can support the user in selecting the appropriate components and parts for their design vision.

### 2.3 BIM Components

There are four main types of arches according to Ching (2012) in his book “A Visual Dictionary of Architecture”, there is the Flat arch, second the Triangular arch, third the Round Arch, and fourth is the Pointed Arch. The Ottoman architecture style of the Hejazi Islamic Architecture Character (HIAC) BIM components library contains right now two types of arches: (between parentheses is the Arabic name)

- 1- Round Arch.
  - a. Segmental Arch (Mawtor or Qawsi).
  - b. Trefoil Arch (Thulathi).
- 2- Pointed Arch (Mudbdab).
  - a. Equilateral Arch (Makhmos).
  - b. Ogee Arch

Those arches are just a sample from the Islamic Architecture Arches Library, provided by the main library of the BIM-driven Islamic Architecture, which is classified, organized, derived from and according to the Islamic styles from the Omai Khilaphia to the Ottoman Khilaphia styles. The figure below appears some of these types.

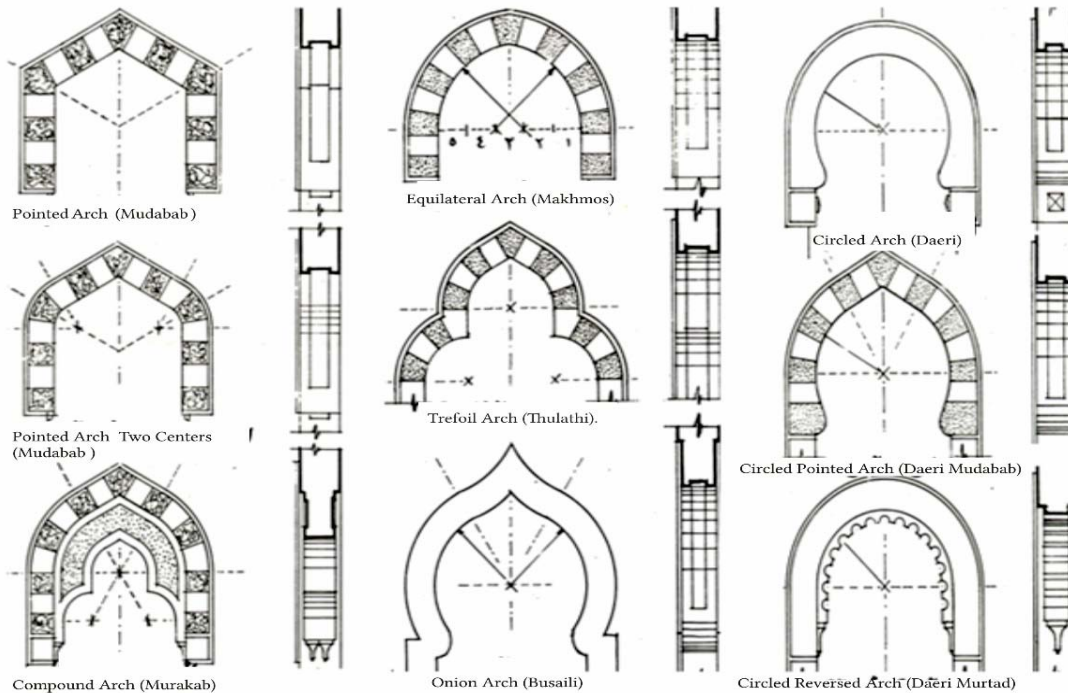

Figure 1: Examples of Islamic Arch (Valley, 2006).

Figure 2 below displays some examples of the common arches included in the HIAC BIM library. Arches are versatile in various positions. They can be found in the main entrance of the house, part of the gallery, and used as a partition to divide halls or large spaces of main rooms. Each Arch of HIAC is either an architectural or structural component that is defined and controlled by its parametric three dimensional representations that is complimented with an attached dataset as described previously.

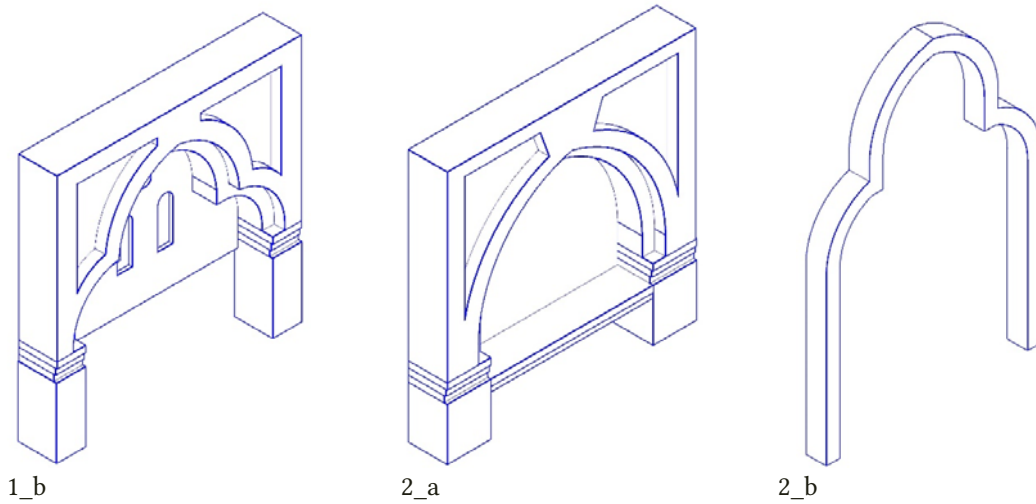

Figure 2 HIAC Arch Types Examples.

Figure 3 below depicts the application of the BIM-IAS library and outlines how BIM-IAS components can be used in projects. Each element's width, length, and depth can be defined to fit specific projects and these changes can be made to either the whole BIM component or only to a specific part of it.

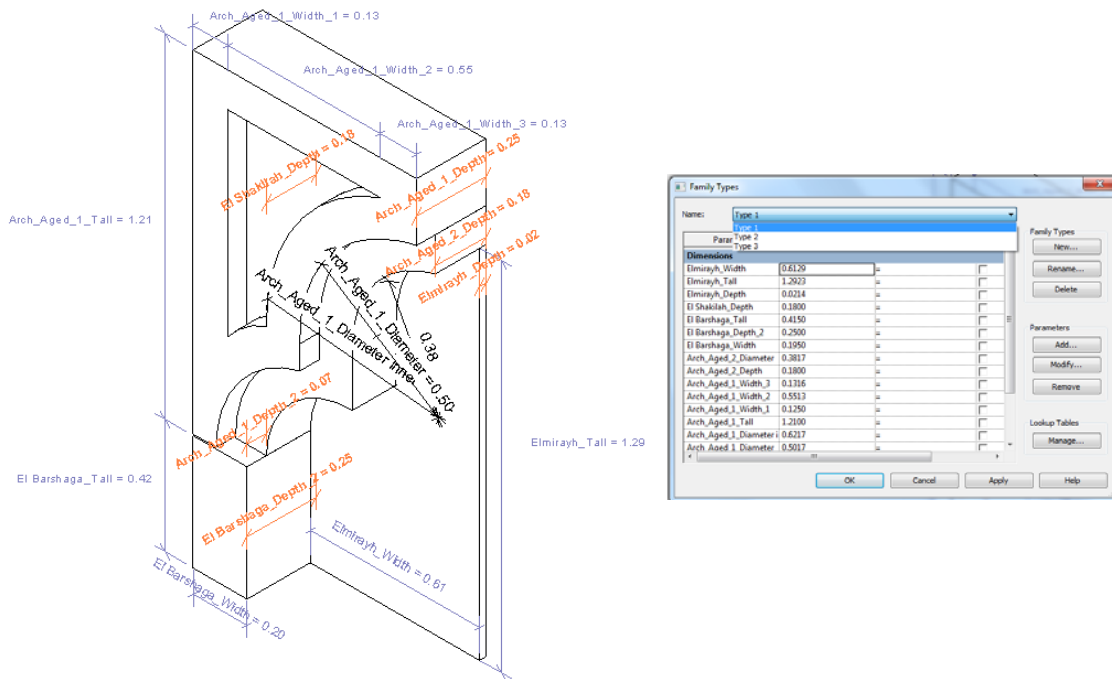

Figure 3 Examples of application of the BIM-driven Islamic Architecture library. (2015b).

Designers can use the BIM library to identify other components to develop the arch design according to their requirements and depending on the predetermined level of simplicity and complexity of the design concept. The figure below demonstrates the features built into the IAS library with respect to the arch section.

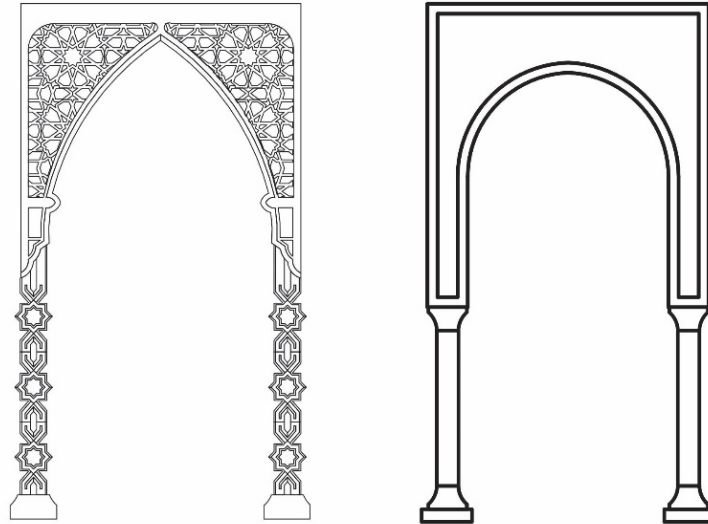

Figure 4. Developed Arches from Combined Components (2015b).

As mentioned previously, arches can be used as a part of the exterior portions of a building or in the interior as wall ornamentations, to support minaret architecture or as structure components. Figure 5 demonstrate some of these examples from a project design.

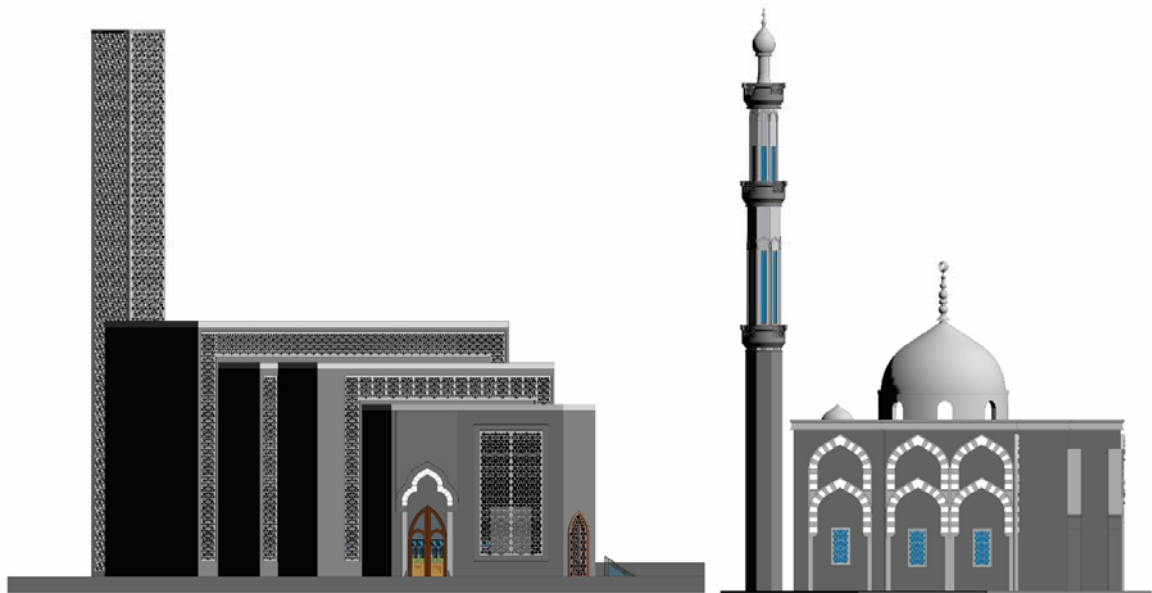

Figure 5. Applying Arches in various projects.

### 3 PLUG-IN APPLICATION

The preliminary interface design of the application plug-in is presented in Figure 6 and it is a part of a plan to build a complete BIM IAS application. This vision has gone through a lot of development and many iterations to get to this point. Previously published research (Almaimani, Nawari et. al 2016) has shown the older versions of the programmed interface and how they were adapted to reach their latest form as shown in Figure 6. The plug in shown in this paper offers a lot of the details regarding the sequence of selecting styles, displaying information, distribution of components, and different features that a designer might seek in an Islamic Architecture Library.

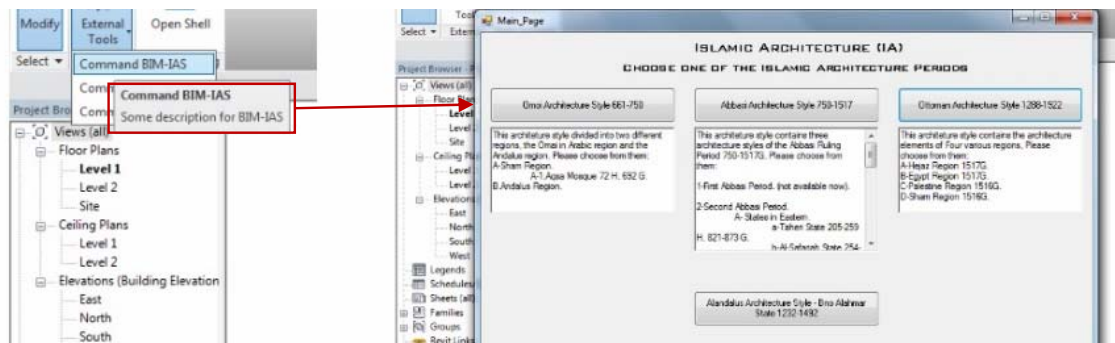

Figure 6. Developed Plug-in for Autodesk Revit.

## 4 CONCLUSIONS

The use of BIM-driven libraries to improve process work flows and integrate intelligent objects into design projects is rapidly being adopted across architectural fields. However, standardized and structured data can be hard to come by especially for less well-known datasets like those found in Islamic architectural styles. This results in resource intensive and complex user fact-finding making project delivery unmanageable. This is of particular concern when the objects used in the design of the project are both historical and varied. Such as the case with the use of Arches that are found in the Hejazi Islamic Architecture. Moreover, current technological solutions are lacking in the amount of data paired alongside structural components, some do not use parametric components that can be adjusted to fit any project, and some are unnecessarily cumbersome resulting in unstable and slow software. This research aims to demonstrate that an alternative solution exists in the form of a BIM-driven library of architectural components used throughout the Islamic world. This paper uses the example of Arches to demonstrate the usability and usefulness of a novel BIM driven tool that can be used by designers to both restore historical Islamic-styled architecture while also serving as a mechanism by which more classical architectural components can be incorporated into modern and contemporary designs.

## Acknowledgements

Authors would like to thank King Abdul-Aziz University, College of environmental Design, Architecture Department, for sponsoring Mr. Ayad Almainani research at the University of Florida.

## Reference

- Albert , . F., Valiente, J. & Gomis, J., 2005. A computational model for pattern and tile designs classification using plane symmetry groups. *CIARP'05 Proceedings of the 10th Iberoamerican Congress conference on Progress in Pattern Recognition, Image Analysis and Applications*, p. 11.
- Al-Lyaly, S. M., 1990. *THE TRADITIONAL HOUSE OF JEDDAH:*, s.l.: UNIVERSITY OF EDINBURGH.
- Almainani, A. & Nawari , N., 2015. *BIM-Driven Islamic Construction: Part 2—Digital Libraries*. Austin, Texas, American Society of Civil Engineers ASCE, pp. 460-467.
- Almainani, A. & Nawari , N., 2016. *BIM-Driven Library for Islamic Architecture*. Osaka, Japan, ICCBE2016 Organizing Committee.
- Almainani, a. & Nawari, N., 2015. BIM-Driven Islamic Construction: Part 1—Digital Classification. *Computing in Civil Engineering*, 21–23 June.pp. 453-459.
- Ching, F. . D., 2012. *A VISUAL DICTIONARY OF ARCHITECTURE*. Second Edition ed. New Jersey: John Wiley & Sons, Inc..
- Djibril , M., Hadi , Y. & Haj Thami , R., 2006. Fundamental region based indexing and classification of

- islamic star pattern images. *ICIAR'06 Proceedings of the Third international conference on Image Analysis and Recognition*, Volume Volume Part II, p. 11.
- Djibril, M. & Haj Thami, R., 2008. Islamic geometrical patterns indexing and classification using discrete symmetry groups. *Journal on Computing and Cultural Heritage (JOCCH)*, 1(2), p. 14.
- Greenlaw, J.-P., 1995. *The coral buildings of Suakin: Islamic architecture, planning, design and domestic arrangements in a red sea port*. London (Bognor Regis, Sussex,): Kegan Paul International Limited.
- Kellum, J., 2015. *Architects Study Buildings of the Medieval Period – Draw A Castle*. [Online] Available at: <https://jackikellumartclasses.wordpress.com/2015/03/23/architects-study-buildings-of-the-medieval-period-draw-a-castle/> [Accessed 6 February 2016].
- Ma, Y. P. et al., 2015. *PARAMETRIC WORKFLOW (BIM) FOR THE REPAIR CONSTRUCTION OF TRADITIONAL HISTORIC ARCHITECTURE IN TAIWAN*. Taipei, Taiwan, The International Archives of the Photogrammetry, Remote Sensing and Spatial Information Sciences, pp. 315-322.
- MA, Y. P., LIN, M. C. & HSU, C. C., 2016. *ENHANCE ARCHITECTURAL HERITAGE CONSERVATION USING BIM TECHNOLOGY*. Hong Kong, The Association for Computer-Aided Architectural Design Research in Asia (CAADRIA), p. 477–486.
- Okamura, T., Fukami, N., Robert, C. & Andres, . F., 2007. Digital Resource Semantic Management of Islamic Buildings Case Study on Isfahan Islamic Architecture Digital Collection. *International Journal of Architectural Computing*, June.5(Volume 5, Number 2 / June 2007).
- Peterson, A., 1996. *Dictionary of Islamic architecture*. first edition ed. london: routledge.
- Ruthven, M. & Nanji, A., 2004. *Historical Atlas of Islam*. s.l.:Harvard University Press.
- The Aga Khan Documentation Center at MIT Libraries, n.d. *Islamic architecture - Aga Khan Documentation Center*. [Online] Available at: <http://libguides.mit.edu/islam-arch> [Accessed 16 February 2015].
- Vallely, P., 2006. *How Islamic inventors changed the world*. [Online] Available at: <http://www.independent.co.uk/news/science/how-islamic-inventors-changed-the-world-6106905.html> [Accessed 16 March 2016].