

---

# RESEARCH ON BUILDING INFORMATION DELIVERY OF STRUCTURAL ENGINEERING FOR COLLABORATIVE DESIGNS

---

Huahui Lai, PhD Candidate, laihuahui81665@sina.com

Cheng Zhou, M.Eng Candidate, sungchou@126.com

Xueyuan Deng, Assoc. Professor, dengxy@sjtu.edu.cn

*School of Naval Architecture, Ocean and Civil Engineering, Shanghai Jiao Tong University, Shanghai, China*

## ABSTRACT

BIM (Building Information Modeling) has brought a comprehensive revolution in the delivery, extraction and utilization of the information in construction industry. In order to ensure the accuracy and completeness of information exchange and share, it requires a targeted definition of information exchange content to meet the specific needs of a particular phase. This paper focuses on definition of procedure and data requirements in design stages, and emphasizes its cooperation with the Information Delivery Manuals (IDM). A BIM-based collaborative design process map is presented, in which the contents in every stage are defined. With these works we developed a specific form of information requirements definition, in which the information delivery involved in this process and the objects and attributes for structure engineering needs are described.

**Keywords:** BIM, delivery, IDM, exchange requirement

## 1. INTRODUCTION

### 1.1 Research background

Building information modeling (BIM) is a computer technology revolution in construction industry as important as CAD (Computer Aided Design). Its application in the building lifecycle could improve construction production efficiency as well as the degree of integration of major projects, and the development of the construction industry has brought great benefits. Among them, AEC projects to promote collaboration between the different professional works are the focus of BIM (Aram et al. 2010). Architectural design and construction is a team activity, including architecture, structure, equipment, budget, operation and maintenance. Throughout the building lifecycle, the data information is constantly creating, accumulating, and transferring and sharing between different software. Therefore, a major goal of BIM development is the exchange of interoperable information (NIBS 2007). In the AEC field, IFC (Industry Foundation Classes) framework is the most comprehensive, object-oriented data model (Froese et al. 1999), covering all stages of project design, and its information meets all business needs of data definitions.

IFC is a neutral and open data exchange format, which is developed by IAI (International Alliance for Interoperability) from 1995. Since 2005 BuildingSMART International took over its maintenance. From the first version IFC1.0 to the latest one IFC2x4 (official name: IFC4), it has been an international open numerical model standard for construction industry. The technological frame of IFC4 composes of resource layer, core layer, sharing layer and domain layer. 800 substantial objects, 358 properties assemble and 121 data types are contained in this version, which indicate the complexity of IFC and the abundance of construction information.

Though the purpose and the achievement of IFC are popularly approved and it has been adopted as ISO standard, it doesn't show its expected advantage in solving the interactive problem in AEC. Since in practice the engineer software bases on a specific purpose and can be only used in some certain stage, it cannot be ensured

that the IFC compatible software can be used in a given task, though IFC supports all the business needs in the whole lifecycle of the project. For each software, the information of IFC is highly redundant. However it can't satisfy the needs of information communication only with "IFC input" and "IFC output" functions in the use interface, while a concrete project-software based data exchange is required. So what is needed is a standard to clearly define the actual work process and the information to be exchanged. Now, the IDM standard is proposed to divide the different stages in a building lifecycle and define the information to be exchanged for each profession in every stage. With this manual the purpose of IFC can be well realized.

## 1.2 Research status of IDM

As an organization devoted to the promotion open-BIM in the building lifecycle, BuildingSMART International (BSI) is the leader in the development of IDM. In 2007, BSI published their first directory of IDM (Wix and Karlshoej 2010). The last one is the version 1.2 published in 2010. In 2010, a specific version of BuildingSMART IDM directory is presented to ISO and eventually becomes the ISO standard, namely ISO 29481-1:2010 Building information models. Information delivery manual. Part 1:Methodology and format (BSI 2010). With development of IDM, more and more scholars take on researches on IDM and its projects.

In 2011 BuildingSMART released Information Delivery Manual: Roadmap (Karlshoej 2011), and confirmed the total 44 IDM projects to be developed corresponding to a certain service type in a certain phase in the building lifecycle, in which 9 have the priority and 5 have the junior priority. So far 20 projects have been developed more or less. This roadmap clarifies the communication layers which are supported by IDM in the building lifecycle, promotes its execution and points out next researches.

In MVD area, the project BLIS (Building Lifecycle Interoperable Software) is carried out to promote execution of software for IFC. The development of IDM and MVD promote the development of IFC-based integrate solution. In BLIS the basic information and the latest researches of MVD are described and released by the Web-based "IFC factory". Besides BSI, other government departments and research organizations, such as US General Services Administration, Statsbygg, Technical University of Denmark and Yonsei University, are independently cooperating with Autodesk, Bentley, Graphisoft and other big software companies. They are researching in some topics on IDM or MVD, among which several have been tested in practical projects. Construction Operations Building Information Exchange (COBie), approval from design to spatial planning, building energy analysis and estimation of construction materials are included in the second version of NBIMS published in 2012 and become the recommended standard in information exchange (NBIMS 2012).

IDM research has been the main topic of BIM. The author studies much documentary, which is mainly published after 2009, indicating IDM is still in the development. The method of IDM development is widely recommended for the process of formulation and implementation on BIM data delivery for the precast concrete industry in the US (Jeong, Eastman, Sacks et al. 2009, Panushev, Eastman, Sacks et al. 2010). Researchers in Regensburg University of Applied Science introduced IDM into the geotechnical construction and described the flow chart and exchange requirements (Obergruesser and Borrmann 2012). Nawari in University of Florida did analysis aiming at structural engineering (Nawari 2011, 2012). BIM Execution Planning published by Penn State University has obtained some achievements in HVAC engineering (Liu, Leicht, and Messner 2012, Lee et al. 2012). However there exist a few documents concerning only conceptual introductions in China (Li and Cui 2011, He 2011), lacking of studied on IDM method or its basic research in an area. In 2010, BIM Research Group (School of Software, Tsinghua University) proposed China Building Information Model Standards (CBIMS), including the standard studies on IFC, IFD and IDM (BIM Research Group 2010), but they primarily focused on solution with software. Researchers in Shanghai Jiao Tong University give a systemic description about the conception, method and actual situation of IDM standard (Zhou and Deng 2012), and begin to study the information delivery standard in the design stage.

Since the needs of information exchange concern about all the phases in the whole building lifecycle, IDM standard cannot be drafted by one single organization and its establishment needs the cooperation of all participants. Our research team has involved in the studies in BIM since a long time and popularized achievements in many famous construction enterprises, such as Shanghai Xian Dai Architectural Design (Group)

## 2. RESEARCH ON BUILDING DELIVERY STANDARD BASED ON IDM

The IDM standard defines the information to be exchanged for each profession in the building lifecycle. And then as IDM target groups, the executive user, the end user and the solution provider make decisions based on exchange information and processes in the building lifecycle. They do not need to know about software development or the IFC model. This paper focuses on definition of procedure and exchange requirements in design stages. The IDM target groups can use IFC data for information exchange in practice, or develop software application based on IFC model.

### 2.1 Information Exchange Framework

IDM is an important part in Information Exchange Framework, as shown in Figure.1. Exchange Framework starts with a well-developed information model which can totally satisfy a specific industry field. In the area of AEC it's IFC, which is the basis of the integrate solution of information exchange.

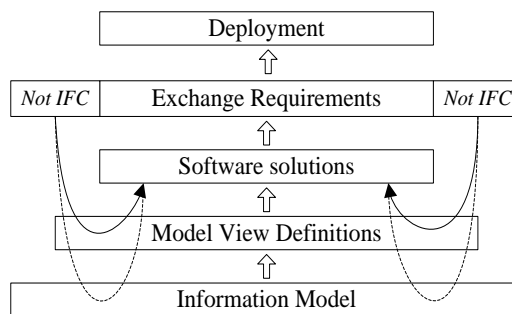

Figure 1: Layers of Information Exchange Framework

The entire framework presents as a pyramid, because the shortcomings of any level limit the possibilities of the above layers. The framework starts with an information model which is developed to meet the requirements of the integrated set of information. And the upper layer of Information Model layer is Model View Definition (MVD). MVD is the set of information from the information model that can be supported by a type of software application. The next one is software solution layer. In order to achieve the purpose of interactive, the software development needs to meet certain criteria, and also needs guidance to meet the specific functional requirements. So it is related with both Model View Definitions layer and Exchange Requirements layer. The upper layer above software solution is Exchange Requirements layer. Exchange Requirement is the core content of IDM. An exchange requirement is the set of information based on special purpose with specified time and place. This information in the exchange requirement does not rely on IFC or software. The top layer deployed to provide users with information about the preparation and software guide to use, in order to promote high-quality information exchange. When focusing on the software solution, the information exchange is defined by IDM and the definition in the data delivery manual is corresponded to the applicable software data by MVD. The software is defined as data aggregate to achieve the exchange requirement in data delivery manual.

### 2.2 IDM components

Figure 2 shows the complete technique structure of the IDM, which includes Process Map, Exchange Requires (ER), Functional Parts (FP), Business Rules (BR), Verification or Validation Tests, and so on.

#### (1) Process Map

A process map defines the flow of activities, actors involved and information required within a particular topic.

(2) Exchange Requirements (ER)

An exchange requirement is a set of information that completely describes particular requirements at a process map. However, the description of exchange requirements is not in technical term. The requirements are provided by the user (architect, engineer, constructor etc.).

(3) Function Parts (FP)

An exchange requirement consists of several function parts. Possibly, every function part is related to other exchange requirements. The information could be described by the function parts which are based on the industry standard information model. For IDM as established, the function parts are based on version of the IFC model.

(4) Business Rules (BR)

Business rules describe operations, definitions and constraints that may be applied to a set of data and properties within a particular process.

(5) Verification or Validation Tests

Verification tests are those which ensure that a stated exchange requirement is being satisfied according to a set of applied business rules.

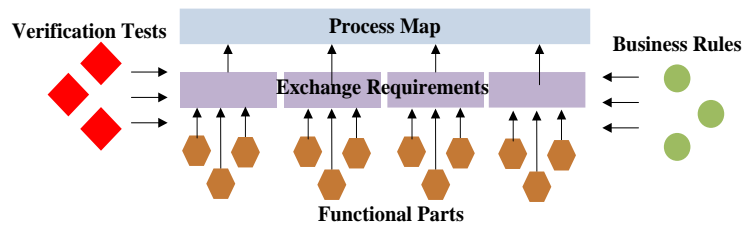

Figure 2: Components of IDM

### 2.3 Engineering design process definition based on IDM

BIM's value chain is closely related to the process integration degree and the continuity of information flow in the full lifecycle. The cooperative work between professional works will become more critical under the BIM design mode. Providing a detailed process definition will help the project members know clearly about their professional responsibilities and tasks, as well as how to communicate with professionals in other fields and share delivery model. In this paper, IDM standard methods are used to define the BIM process in design stages. The process, roles and information flow supported by the BIM tools will be expressed through the flowchart.

(1) Business Process Modeling Notation (BPMN)

The method used in the IDM flowchart is Business Process Modeling Notation (BPMN). BPMN is developed by Object Management Group (OMG), which was officially adopted as the standard of flowchart expression (Wix 2007). The BPMN process model is shown in Figure 3. As to the process described, the tasks are categorized according to the different function aims and the information exchange model is regarded as the separate role type. Flow object, as the basic element of BPMN, is used to describe the working type needed to be done. While Events are used to distinguish the different beginnings and results, Gateways are used to make decisions, which connect with sequence flow and message flow.

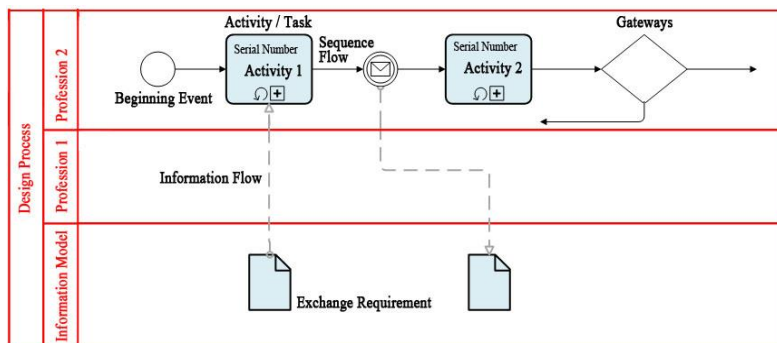

Figure 3: BPMN elaborations in IDM

(2) Standard table description of process definition

In order to standardize the IDM standard, description templates are needed to make in advance. All information involved in making a standard definition should be listed in the templates, and the users only need to fill in the appropriate content. In front of the definition of the whole process is the flowchart description table, as shown in Table 1, which is used to introduce the process definition of professional fields and project phases. These phases are corresponding to the ones defined in ISO. It also includes optional information of author and version number for the sake of revision and management. The detailed description for activities shown in Table 2, which can be divided into three parts: functions, analysis and performance.

Table 1: Brief introduction of process map

Specialty	Architecture/ Structure/ Plumbing/ HVAC/ Electrical	
Project Stage	Outline conceptual design	√
	Full conceptual design	√
	Coordinated design (and procurement)	√
Author		
Version		

Table 2: Process specification

<b>Functions</b>	Functions to be realised in this process: 1./2./3.
<b>Analysis</b>	Activity content (to give more details if it's sub-process): For example, the contents in conceptual design may include architectural spatial planning analysis and building sunlight analysis.
<b>Performance</b>	A simple description of performance: For example, the process of architecture in conceptual design stage can be described as a generalized BIM model including approximate dimensions, shape, location, and orientation. And non-geometric properties may be provided.

## 2.4 Engineering delivery requirement definition based on IDM

Under BIM-based design mode, sharing parametric model is the collection of information, which is much more complicated than what needs to be expressed. The contents of the model include the view and its properties of the contained objects. Objects and properties in different stages and professional fields have different requirements. Therefore a particular exchange requirement is needed to define the contents of every professional field needed to deliver in certain project stage. In the above work, the process node of specific interaction process is defined, and next step is to define the content of information exchange in each node.

The tables of exchange requirement definition are categorized by professional fields, and each table mainly includes model contents created at different stages and model requirements by model receivers. As shown in Table 3, the table should include BIM model objects of every professional field. Every object is the mathematical expression of actual building component. Meanwhile, property information of the objects is added to reflect their physical and functional characteristics. The description column is the brief introduction of the object property information. Other information related to objects or properties can be added to remark column.

Table 3: Template of exchange requirement definition

Object/ Infor- mation group	Attribute Infor- mation	De- scrip- tion	Re- mark	Model author		Model receiver
				Professional code_ER.1	Professional code_ER.2	Professional code _ER. serial number - professional code _ER. serial number
Request in advance						
				R (Require)		
					O (Option)	

In every professional field, the detail level of information, and the contents and properties of the delivery model are various with the different design stages. Therefore, the requirement of the delivery model is defined in the column of model establishing. As to a group of objects and properties, there are totally three options, Require (fill in R) for the necessary properties, Option (fill in O) for the optional ones, and No (fill in nothing) for the ones that certainly with no requirements. Particularly, as to the geometry information, the required detail level of expression is different in various project stages, so it can be expressed as indicative, approximate or accurate, or attaching in the remark column.

Finally, on the base of the model establishing, different model receivers have different requirements for the same model. Still, it can be connected to the various professional flowcharts through identifying with different codes. The way to definition is the same as model establishing, determining required objects and properties by R, O, or not filling.

### 3. INFORMATION DELIVERY CASE ANALYSIS OF BUILDING ENGINEERING

The design of building engineering is a multi-fields collaborative working process, including architecture, structure, plumbing, HVAC, electrical, etc. Designers in various professional fields should finish their own tasks, relying on others. Communication and exchanging exist in the whole process. In this paper, taking the example of structure, the definition of structural design process, the delivery model and required contents are investigated.

#### 3.1 Definition of structural design process

According to the research on the definition of engineering design process in 2.2, the definition of structural design process is given in the following figure, as shown in Figure 4. Every exchange requirement is expressed by information model, and coded according to the naming convention, namely professional code\_ER. serial number. Meanwhile, a model maybe needs to be conveying to several professional fields, and each one needs different contents of this model, which eventually become one part of their own professional communicating model. Therefore, certain convention is used to make the codes, professional code-BIM\_co naming rule, where co is the abbreviation of coordinate, standing for the analyzing type. The professional codes are described in the following refinement professional fields' process, as shown in Table 4.

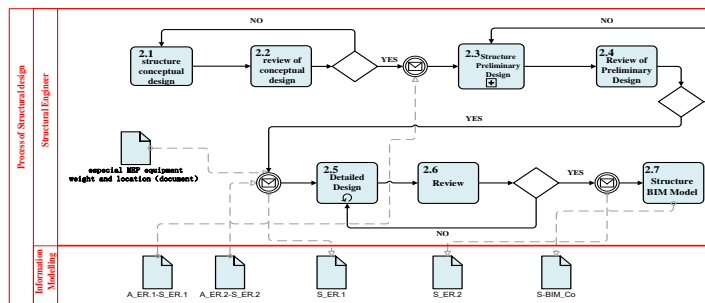

Figure 4: BPMN Process Map of structural design

Table 4: Description of structural engineering process in different stages

Structure Conceptual Design (ID:2.1)	
Function description	Functions to be realised in this process: 1. Determine structural type (such as steel structure, concrete structure , composite structure, etc.) according to certain demand

	2. Determine structural system (such as frame structure, shear wall structure, etc.) according to the height, spatial arrangement and function of buildings 3. Determine spatial arrangement of beam, column, wall, floor and support according to spatial arrangement function and structural system
Analysis	Complicated construction plan needs to be analysed and computed.
Performance	/
Review of Conceptual Design (ID:2.2)	
Function description	Functions to be realised in this process: Check the structural type determined at the plan design stage, and ensure that it is reasonable
Analysis	/
Performance	/
Structure Preliminary Design (ID:2.3)	
Function description	Functions to be realised in this process: 1. Determine the structural requirements for anti-seismic 2. Determine structural load 3. Determine the strength grade of structural materials 4. Determine the cross-sectional dimensions of structural components 5. Complete the relevant preliminary model 6. Accomplish the basic selection and preliminary settings
Analysis	Structural analysis should be done in the preliminary design stage.
Performance	Accomplish the 3D- model making of the structure dimensions
Review of Preliminary Design (ID:2.4)	
Function description	Functions to be realised in this process: 1. Check the rationality of seismic information, load information and member section in extended preliminary design stage. 2. Check structure layout in preliminary design stage.
Analysis	/
Performance	Check and modify structure 3D-model
Structure Detailed Design (ID:2.5)	
Function description	Functions to be realised in this process: 1. Based on preliminary design, structure continued design according to identified structure information is needed. 2. For steel structure, while determining the section of the stressed members, the connection nodes between components and local stiffening measure should be designed in detail. And draw the structure construction model. 3. For concrete structure, while determining the section of the members, member reinforcement and local structure measure should be determined. And design connection nodes and draw the structure construction model.
Analysis	Structure calculation, reinforcement calculation and connecting node calculation
Performance	foundation design, member reinforcement, connecting node design, etc.
Review of Detailed Design (ID:2.6)	
Function description	Functions to be realised in this process: Check structure construction sheets , reinforcement and specification requirements
Analysis	Structure calculation, reinforcement calculation and connecting node calculation
Performance	Examine and prefect the structural BIM model

### 3.2 Delivery requirement of structure modeling

An exchange requirement may cover model contents conveyed by other professional fields in advance, on the basis of which objects of own professional field are added. For example, the structure engineer will receive

architecture model A\_ER.1 in preliminary design, and the required part of the model content A\_ER.1-S\_ER.1 will be extracted, adding the structure objects, and then preliminary design model S\_ER.1 will come into being. Therefore, in the definition table of S\_ER.1, the column of request in advance is filled out with A\_ER.1-S\_ER.1, as a component constituting the exchange model. The structure objects includes beams, columns, slabs, walls, foundation and other basic stressed components, mainly geometric and material information. Due to the space limitations, only delivery requirements of column are listed in this paper, as shown in Table 5.

### 3.3 Analysis of IDM

In this section, structure is taken as an example for introducing the research on the engineering delivery standard on the base of IDM. Besides, the process definition, model delivery and its requirements are analyzed, which indicates the feasibility of the use of the construction information delivery based on IDM. The process and exchange requirement definition table templates put forward in this paper provide a method and a standard, which can be widely used in the information delivery definition of various professional field at every stage of the whole construction lifecycle, including architecture, plumbing, HVAC, electrical and so on.

From the analysis of the information delivery definition in structure, IDM standard provides a concise and understandable language, and makes definition of the information required in every stage and expecting goals at corresponding stage, meeting the demands of users at every stage and improving the quality of information sharing and conversion. Meanwhile, the definition of objects and properties in the exchange requirement does not rely on certain BIM system or software. Instead, the objects are described to meet requirement in design process from the perspectives of architects and engineers. It can be seen that information does not rely on software, and therefore it should be emphasized that software should comply with standards, rather than the reverse case.

IDM standard defines information required at every stage in the building lifecycle, and it also improves the quality of information exchanging, but the above information cannot be utilized by software platforms temporarily. In order to widen the application of IFC standard, it is necessary to combine the definition in the data delivery manual and operational data together, which is called MVD. Through IDM and MVD, the balance between the users' requirements and software development can be found.

## 4. CONCLUSION

In this paper, the IDM standard method is used to draw BPMN process map at the design stage. Besides, Structure is taken as an example to illustrate the new working mode in various building professional fields. The relation of the information sharing and exchanging between different professional fields is clearly defined, on the basis of which particular table templates of requirement definition are established, defining model objects and properties information and different requirements of delivery model at certain stages. Therefore, IDM standard at design stage is established, in order to give reference and basis for investigating the national BIM standard.

The work of IDM next step is to make the information properties described literally correspond to the IFC standard data recorded by computer, and accomplish the model view definition (MVD) which can meet the demands of IFC standard on the basis of particular requirement, using for verifying the IFC sub-model. The special requirement definition table established in this paper is referred to the IFC objects description, highlighting the models and property requirements at different model stages in various professional fields. With continuous optimization and improvement, the exchange between information and software can be realized, which lays a solid foundation for research on MVD.

## ACKNOWLEDGMENTS

This work was a part of Research of P-BIM in Design Stages (P-BIM01B00) from China BIM Standard Research. It was supported by China BIM Development League. The authors would like to thank Shanghai Nuclear Engineering Research & Design Institute for active cooperation.



Table 5: Exchange requirements of structural engineering

Object/ Information group	Attribute Information	Description	Remark	Model author (Structure)		Model receiver (Architecture & Electrical)		
				S_ER.1	S_ER.2	S_ER.1- A_ER.2	S_ER.1- E_ER.2	S-BIM_Co
Request in advance				A_ER.1-S_ER.1	A_ER.2-S_ER.2			
Project / Site								
Project				R	R			
	Personnel information	Basic information and contract way of designers		R	R			
	Professional code	Each participant design specialty has a unique ID.	Structure can be defined as S.	R	R			
Site				R	R			
	Geometrical position	Province, city, county	For determining the seismic fortification intensity	R	R			
	Ground type	I、 II、 III、 IV		R	R			
	Ground geological data	Characteristics of soil layer bearing capacity		R	R			
Structure components								
column				R	R	R		R
	ID	Unique identifier of column elements		R	R	R		R
	Metadata			R	R	R		R
	Position coordinates			R	R	R		R
	Shape	Section shape Entity type		R	R	R		R
	Section Geometric Characters	Dimensions, Inertia moment		R	R	R		R
	Height			R	R	R		
	Material			R	R	R		
	Strength grade	C25, C30, etc.		R	R	R		
	Connection			R	R			
	Reinforcement				R			

## REFERENCES

- Aram, V., Eastman, C. M., Sacks, R., Panushev, I., & Venugopal, M. (2010). "Introducing a new methodology to develop the information delivery manual for AEC projects". *Proceedings of the CIB W78 2010: 27th International Conference*, Cairo, Egypt, 49-59.
- BIM Research Group (School of Software, Tsinghua University). (2010). "Research on Chinese Building Information Modeling Standard Framework". *Journal of Information Technology in Civil Engineering and Architecture*, 2, 1-5.
- BSI. "ISO 29481-1:2010, Building Information Modeling-Information Delivery Manual- part 1: Methodology and format". (2010).
- Froese, T., Fischer, M., Grobler, F., Ritzenthaler, J., & Yu, K. (1994). "Industry foundation classes for project management - a trial implementation". *ITcon*, 4, 17-37.
- He, G. P. (2011). "The Three Pillars of BIM-IFC/IDM/IFD". *Journal of Information Technology in Civil Engineering and Architecture*, 3, 108-116.
- Jeong, Y. S., Eastman, C., Sacks, R., & Kaner, I. (2009). "Benchmark tests for BIM data exchanges of precast concrete". *Automation in Construction*, 18, 469-484.
- Karlshoej, J. "Information Delivery Manual: Roadmap". [http://iug.buildingsmart.com/idms/roadmap/IDM\\_Roadmap\\_1\\_1.pdf/view](http://iug.buildingsmart.com/idms/roadmap/IDM_Roadmap_1_1.pdf/view). (10/12/2011, 2011).
- Lee, S., Liu, Y., Chunduri, S., Solnosky, R., Messner, J., Leicht, R., & Anumba, C. (2012). "Development of a process model to support integrated design for energy efficient buildings". *Proceeding of the 2011 ASCE Int. Workshop on Computing in Civil Engineering*, Miami, Florida, USA, 261-268.
- Li, C. S., & Cui, L. (2011). "Research on Collaborative Design Standard Based on IFC". *Journal of Information Technology in Civil Engineering and Architecture*, 3, 1-4.
- Liu, Y. F., Leicht, R., & Messner, J. (2012). "Identify information exchanges by mapping and analyzing the integrated heating, ventilating, and air conditioning (HVAC) design process". *Proceeding of the 2012 ASCE Int. Workshop on Computing in Civil Engineering*, Clearwater Beach, Florida, USA, 618-625.
- National Institute of Building Sciences. (2012). "United States National Building Information Modeling standard version 2".
- Nawaril, N. (2011). "Standardization of structural BIM". *Proceeding of the 2011 ASCE Int. Workshop on Computing in Civil Engineering*, Miami, Florida, USA, 405-412.
- Nawaril, N. (2012). "BIM standardization and wood structures". *Proceeding of the 2012 ASCE Int. Workshop on Computing in Civil Engineering*, Clearwater Beach, Florida, USA, 294-300.
- NIBS. "United States National Building Information Modeling Standard version 1-Part 1: Overview, principles, and methodologies". (2007).
- Obergriesser, M., & Borrmann, A. (2012). "Infrastructural BIM standards-development of an information delivery manual for the geotechnical design and analysis process". *EWork and EBusiness in Architecture, Engineering, Construction*, 581-588.
- Panushev, I., Eastman, C., Sacks, R., Venugopal, M., & Aram, V. (2010). "Development of the national BIM Standard (NBIMS) for precast/prestressed concrete." *Proceedings of the CIB W78 2010: 27th International Conference – Cairo, Egypt*.
- Wix, J. "Quick guide: business process modeling notation". <http://iug.buildingsmart.org/idms/methods-and-guides>. (8/1/2007, 2007).
- Wix, J., & Karlshoej, J. "Information delivery manual guide to components and development methods". <http://iug.buildingsmart.org/idms/methods-and-guides>. (5/12/2010, 2010).
- Zhou, C., & Deng X. Y. (2012). "Research Status and Methods of Information Delivery Manual". *Journal of Information Technology in Civil Engineering and Architecture*, 4, 22-27,38.