

Generic Process Template Description for the Effect of Risks on Project Schedule

Raimar J.Scherer³, Wael Sharmak⁴

ABSTRACT

Many factors impact construction projects and cause changes in the project management plans. These factors can be considered as risks which are impossible to be identified completely in early project stages. Therefore, risk management in construction requires proactive as well as reactive procedures. Risk treatment, among the other risk management subprocesses, has the concrete change action which may modify one or more of the project management plans. In this paper, process modeling techniques are used to describe risk treatment effect on the structure of the project schedule plan. This structural change description is introduced as formalized configurable treatment templates. According to our findings seven generalized templates are efficient to represent the risk part in project reference models concerning process changes which in turn can be tailored and assembled to form up-to-date schedule plans. This kind of risk representation in reference repository will serve as means of knowledge management by providing all risk-related available information as response to a critical event. The Event-driven process Chains (EPC) will be used to model risk treatment templates using normal and configurable EPC elements.

KEY WORDS

Process Modeling, Risk Treatment, Configuration, EPC.

1. INTRODUCTION

In the construction industry no project ever goes totally as planned, because of the effect of some unforeseen risks which are often beyond anyone control. Risks may occur suddenly and consequently will cause problems after a project task execution is started. As a consequence of a risk, changes may occur in the project cost estimate, schedule baseline, or recourse requirements and hence task rework may be needed. This may result in project delay, in critical or near-critical activity-cases, and project cost overrun. Therefore, it is required to readjusting the project management plan (schedule, cost, procurement, resources, risk etc) according to the new situation. The changes in the project plan can be caused by external or internal factors. External factors are such as technological changes, government and policies, or customer's expectations and preferences. Internal factors are like, management policy, or organizational objectives (Sun et al 2006) and (Gehbauer et al 2007). Particularly, construction-driven risks such as soil and ground conditions and possible accidents are difficult to assess. Moreover, maybe also sever design-driven risks such like design changes that result from changes in owner requirement as well as design errors induced by short design times and the uniqueness and complexity of the products. These risks are often recognized at a later stage of the project and often require considerable redesign and rework.

In this paper, only the change effect of these risks on the schedule plan will be discussed using process modeling techniques as risk treatment templates. The focus on risk treatment process and not on the total risk management cycle comes from the fact that concrete change action of the risk management is done only by executing risk treatment plans. Event-driven process Chains (EPC) method will be used to develop risk treatment templates as configurable scenarios, which can be configured to show the most likely, optimistic, or pessimistic cases, and therefore can be utilized in virtual or actual situations. This paper is structured as follows. Firstly, we will start with a general overview about risk management with deeper look at the risk treatment process. Secondly, the principles of the used modeling method "EPC" will be explained in its two parts; the normal and configurable one, and the reason behind choosing this method to model schedule change risks will be presented. Thirdly, the suggested treatment templates will be introduced with brief explanation about the usage of each one of them. Finally, the paper will be concluded and further work steps will be mentioned.

³ Professor, Head of the Institute, ² PhD Candidate

Institute for Construction Informatics, Dresden University of Technology. 01062 Dresden, Germany

Email: { Raimar.Scherer, Wael.Sharmak }@mailbox.tu-dresden.de.

2. RISK TREATMENT IN AEC

According to the established risk management standards (AS/NZS 4360, 1999 - PMBOK Guide, 2004), any risk management typically includes a series of the following tasks: (1) identification, (2) assessment, (3) treatment planning, (4) treatment, (5) monitoring, and (6) documentation.

Risk treatment is assumed in this work to be consisted of two parts; proactive and reactive treatment, figure 1 shows the two cycles of proactive and reactive risk management. Proactive treatment is the traditional known type within risk management in which only anticipated high probability/impact risks, according to the agreed thresholds, are treated by executing the planned treatment strategies. This is typically done before execution starts or at least before the risk evolves to a real problem and affects the targeted activities. However, another type of risk treatment, reactive treatment, obtains increasing attention in construction industry because of the following reasons:

1. It is impossible to identify all potential risks in advance. As it is inevitable that some risks often arise as a result of completely unpredictable events, e.g. human errors, even if all proactive risk identification techniques have been applied.
2. Even if a risk is identified, it can be for some reason underestimated during preliminary assessment, e.g. because of lack of reliable information and therefore was excluded from the proactive risk treatment group.
3. In addition, there is a tendency in the construction industry to leave probable risks and react to them when they have occurred, rather than dealing with them in advance, see (Loosemore et al 2006).

Therefore, there is a need to react effectively and efficiently to these risks using appropriate reactive treatment procedures.

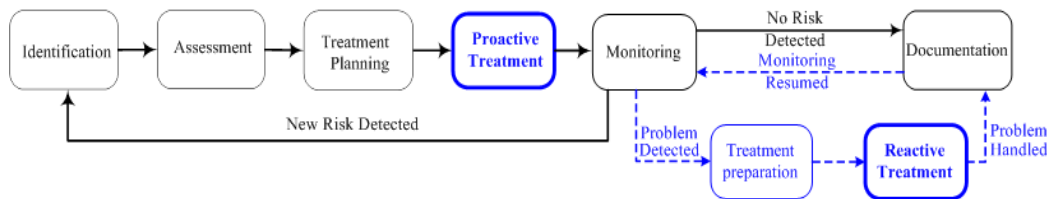

Figure1: Proactive and reactive treatment cycles within RM process.

In accordance with the reactive/proactive treatment types, the following ways of change in the project schedule can be realized:

- 1- The project schedule baseline will not change, but some changes may be needed in the resource plan, or the cost plan, e.g. in the case of cost overruns caused by higher material costs than what was estimated before.
- 2- Changes in the project plan are done as proactive treatment, i.e. before a risk evolves to a real problem. This kind of changes most probably happens in the pre-construction phase and it may be done for example by adopting new construction methods to avoid falling in risks. In the case of proactive treatment planned within the preconstruction phase, counteractions are included as a part of schedule baseline before the construction starts, resources are respectively assigned to execute these measures. Another example of proactive treatment is by incorporating additional time as contingency reserve into the overall project schedule as recognition of schedule risks.
- 3- Changes in the activity-sequence of the schedule plan must be done in a dynamic way to represent the undertaken countermeasures and to detect their effects on planned interrelated activities. More than one planned activity may suffer from different changes as a response to one risk, e.g. canceling, substituting, or even inclusion of an activity may need to be followed by recourses leveling for the successor logically-dependent activities to keep the deadline of the contract.

3. EVENT-DRIVEN PROCESS CHAINS (EPC)

EPC is a method developed within the frame of Architecture of Integrated Information Systems (ARIS) (Keller et al. 1991), to model business processes. It is a graphic modeling language and its visual notation

consists mainly of Events, Functions, logical connectors, and control flow. EPC describes business processes by creating a chronological sequence of events, functions and their logical interdependencies using logical connectors.

3.1 NORMAL EPC

Functions in EPC represent activities to be executed. Each function can be refined into another EPC and it is called in this case a hierarchical function. A function is represented as a rounded rectangle (see figure 2). While events are the passive elements in EPC, i.e. no decision is made using an event as it describes only the pre-state or the post-state of a function. Events are represented in the EPC process model as a hexagon. A control flow is an arrow connecting events, functions, and connectors with each other creating chronological sequence between them. Connectors in EPC show the logical relationships between the elements (function-event, event-function). A connector may split the control flow to more than one path, or join more than one path in one control flow. These types of connectors are, AND connectors, Inclusive OR connectors, Exclusive OR (XOR) connectors.

There are some roles controls the usage of EPC to represent a process model and guide its design, like:

- 1- Because EPC is an event-driven modeling method, it has no function-function or event-event connections since each function follows a generating event and in the same time it is followed by a generated event.
- 2- Only connectors are allowed to branch, nor events neither functions.
- 3- Split connector of type (Event-to-Function) cannot be of type "XOR" or "OR", because the event is a passive element which means that the event cannot be used to make decisions. It can be used only to trigger parallel activities using AND connector.
- 4- Logical connector should match, which means that an opening XOR serving as a branch should be closed by another XOR connector. The same rule applies to fork/join using AND connector and OR connector.

Event-driven Process Chains method is chosen in this work to model risk treatment effect on the project schedule plan because EPC can support some special features, which are very suited to this issue:

- 1- As its name indicates, it is an event-driven method used to model business processes. This makes it suitable to represent risks as "deviation or problem" events in the process model and to show treatment as a response activity to the risk event. Such kind of representation is not possible in normal project scheduling methods.
- 2- EPC method supports configurable modeling, as it has some specification to represent configurable elements within the developed process model. Configurable modeling can be beneficially applied in risk treatment modeling, because risks are uncertain events which may occur and may not, so it will be wrong and will not reflect the actual reality of a risk and countermeasures to be modeled as normal elements. So the assumed best solution here is to represent risk and treatment measures as configurable part in the model which can be configured as adopted "normal" elements in case of risk occurrence and can be skipped in normal situations.
- 3- EPC was introduced as a modeling concept to represent temporal and logical dependencies in business processes (Keller et al. 1991). Therefore, EPC can be seen as a Precedence Diagram Method (PDM) with some advantages due to suiting IT requirements, databases etc. In addition to it can be extended, i.e. using extended EPC (Scheer 2000), to include resource limitations for each activity.

3.2 CONFIGURABLE EVENT-DRIVEN PROCESS CHAINS (C-EPC)

Configurable EPC extends regular EPC to allow for the specification of configuration connectors and configuration functions in process models. In this extension of normal EPC, configuration elements have been identified to highlight distinguishable configuration alternatives. These elements can be classified in the following types:

- 1) Configurable functions: A configurable function may be included (ON), skipped (OFF) or conditionally skipped (OPT). It is represented as grey highlighted rectangle with bold border, see figure 2.
- 2) Configurable connectors: A configurable connector may only be mapped to a connector type that restricts its behavior (Rosemann & van der Aalst 2003). C-OR connector for example can be configured to normal OR, normal XOR, normal AND, or mapped to a single sequence of events and functions (SEQ). All configuration constraints for the configurable connectors are summarized in table (1).

	OR	XOR	AND	SEQ
OR ^C	X	X	X	X
XOR ^C		X		X
AND ^C			X	

Table. 1: Constraints for the configuration of connectors (after Mendling et al. 2005)

- 3) Sequence relationships: The sequence relationships connect variation points with either mandatory rules (Configuration requirements) or optional rules (configuration guidelines) to facilitate the configuration of the model. They are defined via logical expressions in the form of if-then statements.

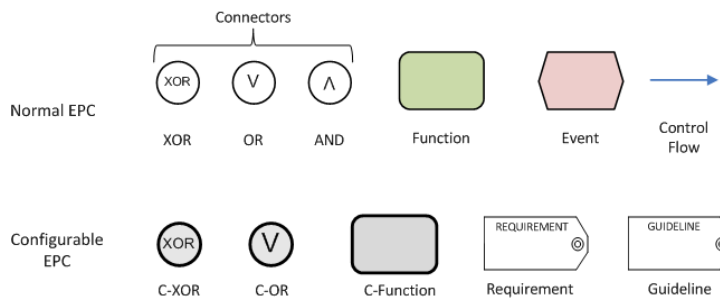

Figure2: Normal and configurable EPC elements

4. CONFIGURABLE RISK TREATMENT TEMPLATES

Our hypothesis is that all possible ways of schedule change as a response to probable/actual risks can be standardized by generalized risk treatment templates. Seven treatment templates are suggested in this work. A template can be identified as a case-oriented configurable process model which describes the possible risk-related scenarios as configured process models. Only one of these scenarios will be used to represent the actual or virtual structural change in the schedule plan caused by a specific risk event. Risk treatment templates are classified in two main groups, proactive and reactive risk treatment templates. If-then statements are used as requirements to control the configuration alternatives. In these statements the used expression RISK=ON means that the specific risk parameters has exceeded the agreed threshold in the proactive treatment cases. In reactive treatment it means that the risk has evolved to a real problem and the required change has been approved. RISK=OFF indicates the opposite. In these templates also treating each risk requires a function named "treatment". This function as hierarchical one can be refined into another EPC, which shows the details of the needed actions to handle the specific risk-task case. Risk treatment can affect, directly or indirectly, multiple logically-related tasks. After the problem in the affected task is treated, other problems may come to surface as indirect effect of the last treatment and in turn needs to be handled, e.g. durations and dates readjusting or resources leveling, this is not considered in our work. Anyhow, the treatment of a task can show which and how the parameters in the dependent tasks will change and according to this individual and sequential treatments may be carried out to keep the project plan within the imposed constraints.

4.1 PROACTIVE RISK TREATMENT TEMPLATES

We have identified four different templates for proactive and three for reactive risk treatment, which are described in the following:

4.1.1 INSERTION CASE

In the insertion template, see figure (3-1), the treatment is done before the risk evolves to a real problem, i.e. at least before the affected function (n) starts. When it is obvious that the risk event has a considerable probability/impact on the targeted activities according to the agreed tolerance thresholds, then the treatment

function will be included in the schedule plan. When the decision will be made to treat the risk event in advance in a proactive way, the needed resources will be assigned to execute the proactive treatment tasks and its needed cost and time will be considered in the general project cost and schedule. Some proactive treatment measures will already be done before the execution will start, i.e. in the planning phase of the project by avoiding or transferring the expected risks and consequently the countermeasures will not appear in the project plan.

4.1.2 SUBSTITUTION CASE

Assume that an identified risk is considered not a threat to the project objectives, because the assessment showed that its probability of occurrence is below the thresholds. After construction started and according to more reliable information, the risk has been found to be more dangerous than it was expected. As a countermeasure to the expected danger, certain activities may need to be substituted with other activities which are more suited to the new situation. Also it can be the case when a new risk not identified before, appears to the surface and according to the study of the characteristics of this risk it was found that the substitution of some present activities with more suitable activities will be the best solution. In this template shown in figure (3-2), function (n) is substituted with function (m) to eliminate/avoid/mitigate the highly expected high risk impact. This alternative function, function (m), was not preferred in normal cases because of, e.g. its higher cost, its longer duration, or may be because it is technically more complicated to be executed.

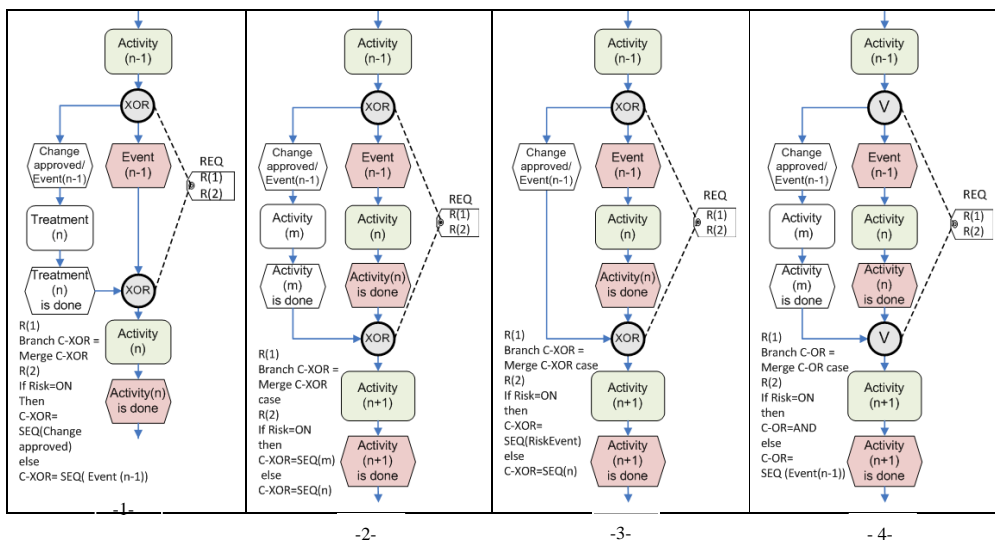

Figure 3: Proactive risk treatment templates

4.1.3 CANCELATION CASE

The cancellation template, figure (3-3) can be used for example (1) in the case when a threat becomes highly expected, and some changes must be done as a proactive response to the coming danger by canceling some planned tasks and adding other new tasks somewhere else in the project plan, so at first the cancellation template will be used and after that the insertion template. Also (2) it can be used in the case when some tasks are planned to handle an expected risk case, and after the execution started more reliable information were obtained indicating that the risk is not anymore to be considered as a threat, and hence these planned tasks can be canceled.

4.1.4 PARALLELISM CASE

In the parallelism template shown in figure 3, the needed activities to treat anticipated risk will be undertaken in parallel with some planned functions, in this case a configurable OR is used and an If-Then requirement

will limit its configured scenarios to two models only: (1) AND in case of parallelism, (2) normal sequence in the normal situation, i.e. when RISK= OFF.

4.2 REACTIVE RISK TREATMENT TEMPLATES

In the three reactive templates, risk event will interrupt and stop “temporarily” the execution of a function. This risk event was (1) not expected and therefore not prepared against before, e.g. very bad weather or supply delay, or (2) it was thought to be within the accepted thresholds but its real effect was much bigger than what was expected, also (3) it happened suddenly hence was not handled in proactive way such as human errors.

In these templates three important elements appear:

1. The risk event: in reactive treatment, risk will appear in the model as interruptive event which will be located between the interrupted function and its finishing indicator event.
2. Treatment preparation function: it is impossible to start the treatment immediately after the risk occurrence, as some intermediate measures may be needed, such as problem analysis, treatment planning and/or decision making. The needed preparation measures may differ from case to case according to different factors, for instance staff experience and risk characteristics.
3. Resuming function: in all reactive templates the function is interrupted, which means that it will be stopped temporarily, this function need to be resumed after the risk is treated. The resumption appears as a function called “Function Resuming” which will be located directly before the function finishing indicator event. The interruption concept adopted in this work is explained in Ofigure 4. Assume that function B is interrupted; this function can be refined as a hierarchical function to some atomic functions. The interruption may be assumed to occur between two atomic functions and not in any one of them. All the atomic functions before the interruption can be merged in one “pre-risk” function. The functions after the interruption can be merged in a “post-risk” function, which is represented as “Function Resuming”. The risk event and the following treatment action will be located between the pre- and post-risk function parts. In our developed templates the pre-risk function will inherit the name of the interrupted function.

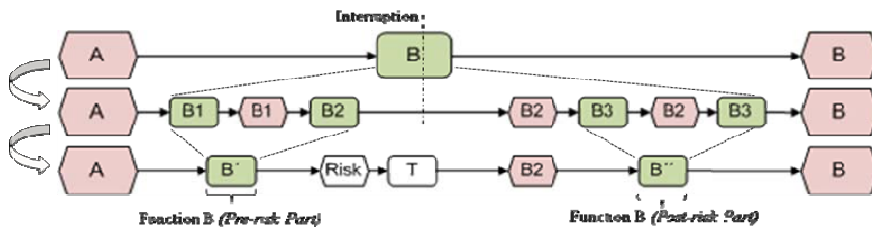

Figure 4: Interpretation of Function interruption in EPC.

4.2.1 TREATMENT TEMPLATE

Risk (1n) in figure (5-1) was not expected before or it was thought that its probability/impact will be within the accepted thresholds. But risk (1n) evolved to a real problem and interrupted Function (n). Therefore Treatment (1n) is needed to handle the risk, after Function (n) can be resumed. As the risk occurred, the configurable XOR connector will be mapped to a sequence of events and functions containing (1) the risk event, (2) treatment preparation function, (3) the treatment function and the (4) Function resuming. Otherwise the configurable connector will be mapped to a sequence from the function to its finishing indicator function without encountering any disturbance.

4.2.2 TREATMENT TEMPLATE

Stop template, shown in figure (5-2), is a special case of the treatment template. It represents the negative reaction to the risk, the risk event will delay the function execution and nothing can be done except waiting until the risk bad effect will be finished, e.g. the case of unexpected very bad weather or natural hazard which will stop the work in the outdoor activities until the conditions become better.

4.2.3 PARALLEL ACTIVITIES CASE

In the case a risk will interrupt some parallel tasks. All affected parallel paths will need to be merged in one path, on which the treatment of this risk will take place. After the treatment is done the risk effect is finished. The path can be splitted again to the same old paths and the interrupted tasks will be resumed and after that the successor planned tasks will be executed in parallel as planned, see figure (5-3).

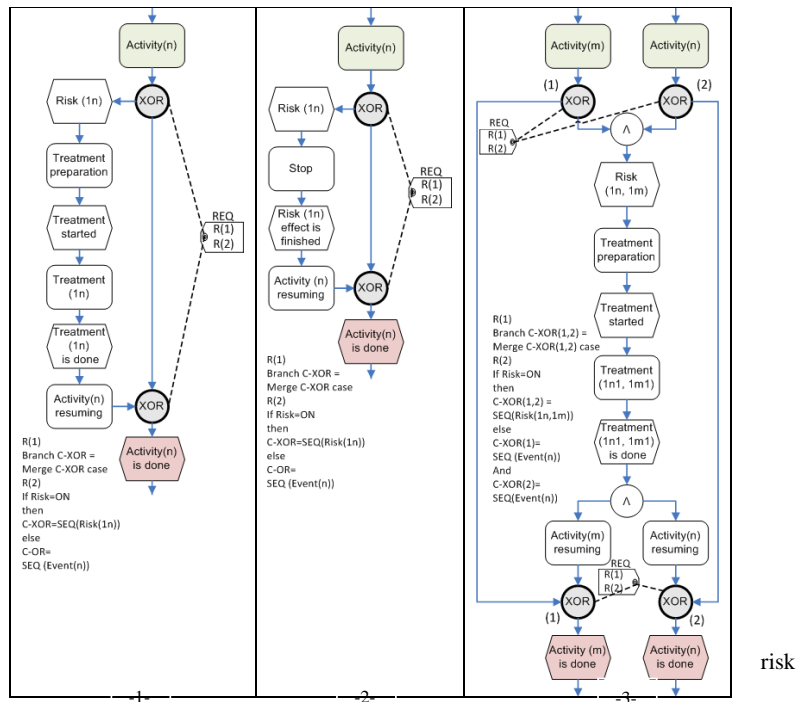

Figure 5: Interruptive treatment template

4.3 CONFIGURATION EXAMPLE

In figure 7, the configurable model shows that the Function (n) may be interrupted by risk (1n) two treatment methods (T, T2) are available to handle this risk. Therefore, decision making is needed to choose the most suitable case for the situation at hand. Configuration alternatives are controlled by logic statements. The first requirement R (1) insures that the merge C-XOR has the same case like the branch C-XOR case. Consequently no deadlock will occur in the process model. R (2) limits the possible configuration alternatives in the C-XOR connector to the only needed cases, here only the sequence cases, and determines which configured state is needed in which condition. The third requirement R (3) represents a second level of configuration, as it will control that only one treatment action from multi-possible methods will be chosen. In the first illustrated configured model risk did not occur, i.e. Risk=ON is false. Therefore the empty sequence path will be chosen as value for the C-XOR, which means that the function will be executed without any disturbance. In the second configured model the first level of configuration is adapted as RISK=ON is true and risk event appears after the function in the model. This means that Risk (1n) sequence path is chosen as a value for the C-XOR connector. In the third configured model the decision was made to approve the method (2) to treat the risk by adopting C-XOR value equal to SEQ (T2) as T2=True.

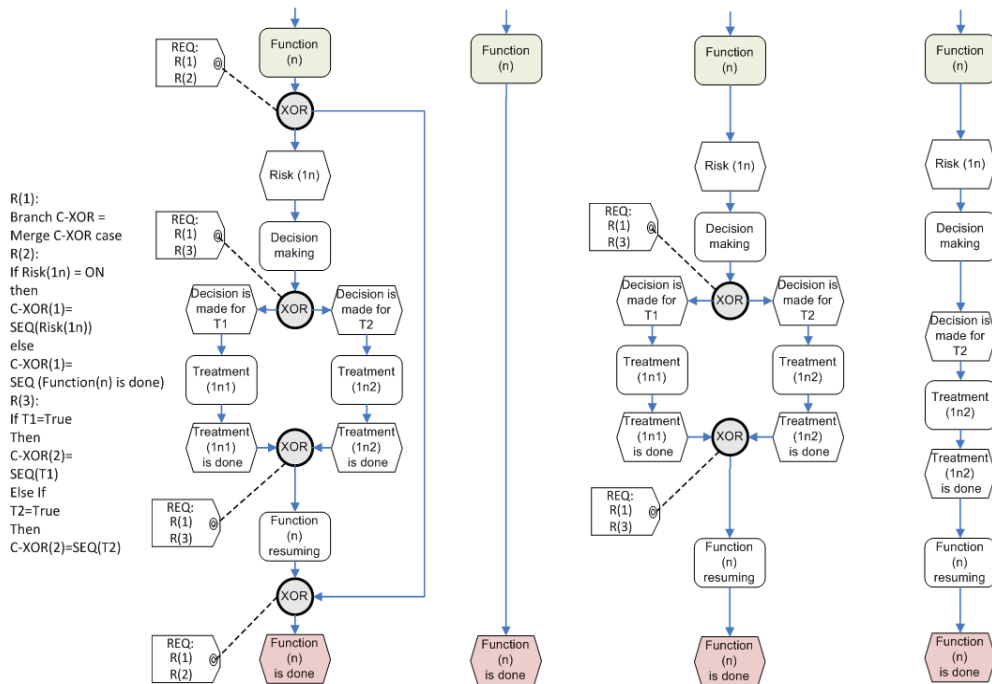

Figure 7: Configuration alternatives of a configurable RRT

5. CONCLUSIONS AND FURTHER WORK

EPC was used in this work to represent the possible change in the schedule structure using normal and configurable EPC elements. These changes were ascribed to risks that may affect the project schedule plan. Therefore, the changes occur as response to the anticipated high probability/impact as well as to already occurred risks. Responses to these risks which may change part of the schedule are designed as configurable risk treatment templates since treatment task carries out the planned change in other risk management tasks. The configurable templates can be adapted to the case which suits the actual situation by including the configurable template as a normal part in the process model when “RISK= ON” case is true, or by deleting this path from the process model if “RISK = ON” case is false. Each configurable risk treatment template illustrates one way of risk-caused change in the project plan. However each risk can cause more than one way of change so more than one template may be needed to express the changes caused by one risk. These templates will not show how to treat a risk, since they describe only the changes in schedule structure which can suit many kinds of risks or risky situations. Therefore, a risk-treatment database is needed to describe the known risks and the related alternative treatment methods associated with each construction task/deliverable. This database must be designed and linked to the specific project process model. Such database will give the needed level of detail about the needed treatment. The description of the data model and the structure of this risk-treatment database is one of the next steps of this work.

REFERENCES

AS/NZS 4360.(1999): Risk Management Standards, Australia.
 Gehbauer, F., Zülch, G., Ott, M., Börkircher, M., (2007): Simulation-based analysis of disturbances in construction operations. Proceedings of the International Group for Lean Construction fifteenth conference (IGLC-15), Michigan, USA.
 Keller, G., Nüttgens, M., Scheer A.-W., (1991): Semantic process modeling based on „ Event-driven Process Chains (EPC). (published in German). Publications of the Business Informatics Institute, Report 089, Saarbrücken. Available electronically on: <http://www.iwi.uni-sb.de/Download/iwihefte/heft89.pdf>.

- Mending, J., Recker, J., Rosemann, M., van der Aalst, W., (2005): Towards the Interchange of Configurable EPCs: An XML-based Approach for Reference Model Configuration. In: J. Desel, U. Frank, eds.: Proceedings of the Workshop Enterprise Modelling and Information Systems Architectures (EMISA 2005), Vol. 75 of Lecture Notes in Informatics (LNI, Klagenfurt, Austria, pages 8-21.
- PMBOK Guide. (2004): A Guide to the Project Management Body of Knowledge, Project Management Institute, Pennsylvania, USA.
- Sharmak, W., (2007): Construction Risk Treatment Templates Using Configurable Modeling. In: Merkel, A.P. Schütz, R. and Wießflecker, T. (eds.): Proc. Forum Bauinformatik 2007, Verlag der Technischen Universität Graz, Austria.
- Fettke, P., Loos, P. (Eds), (2007): Reference Modeling for Business Systems Analysis, Idea Group Publishing
- Loosemore, M., Raftery, J., Reilly, C., Higgon, D., (2006): Risk Management in Projects, Taylor & Francis Group, London & New York.
- Scheer, A.W. (2000): ARIS-Business Process Modeling, Springer Publishing, Berlin, Germany.
- Sun, M., Senaratne, S. Fleming, A., Motowa, I. and Lin Yeoh, M.(2006): A change management toolkit for construction projects, Architectural Engineering and Design Management, University of the west of England, University Press/Springer-Verlag, UK.