

Theme:

Title: **Evolution of a Road Product Model**

Author(s): Danijel Rebolj, Nenad Čuš-babič, Andrej Tibaut, Aleš Magdič

Institution(s): University of Maribor, Faculty of Civil Engineering, Construction IT Centre

E-mail(s): rebolj@uni-mb.si

Abstract: *Product modelling concepts, methods, techniques, and experiences have reached an evidently higher level of maturity and applicability. This paper presents the evolution of the road product model PMC from its first concepts in 1993 to the latest application, which is based on the XML technology and on the network concept of the Virtual Product Model. The paper compares the PMC with other existing road models, the RSMK, OKSTRA, and the Swedish National Road Administration model.*

*One of the main characteristics of the PMC are its simplicity and modularity, which have been intentionally preserved from the earliest version, although there have been plans to essentially extend the model and its complexity in the meantime. The paper explains the reasons for such directives.*

*Furthermore, applications based on the latest version of the PMC road product model are presented. The paper concludes with a discussion on the effectiveness of different product modelling concepts and summarizes the relevant experiences gathered by the authors.*

Keywords: *Product modelling, road product model, interoperability, XML, Virtual Product Model*

## Introduction

Product modelling concepts, methods, and techniques have already been described often enough to be seen as standard knowledge in the field of construction information technology (ITC). The main idea of the product model is in structuring and integrating in a single model all relevant data, needed in all computer supported phases of the life-cycle of the product (Björk 1989). The main problem of product models is their complexity, which rises as a model approaches the purpose it should fulfil (Eastman and Augenbroe 1998, Turk 1999, Rebolj and Tibaut 2000).

The other essential problem is represented in the definitions of the basic elements of complex structures. This problem is being resolved specifically in different engineering fields. In case of construction special STEP application protocols have been developed to describe structural elements (e.g. AP225, which describes the structural elements through the explicit formative representation). Such application protocols have been developed slowly and were not in the main focus of the general interest. In order to accelerate the standardisation of basic elements in 1994 the International alliance for interoperability (IAI) has started to develop their own standard, IFC (Industry Foundation Classes, IAI 2002). IFC uses the 3D object-based CAD concept, which is quickly emerging as the new standard CAD rationale for the industry. The IFC standard is a single object model, a set of elements for the building industry, which is created in consideration with the STEP standard. On the other hand, the IFC standard is not following the free and open STEP concept because it defines sets of elements within the boundaries of IAI partners, which mostly are large software developers.

In recent years the eXtensible Markup Language (XML) is being developed very fast as a new Internet language and technology. With XML product models can be described as XML schemes, although XML hasn't been developed for such purpose primarily. It does, however, have a wide support in the Internet community and therefore a strong background of developers and users. A web page can be defined in XML instead of HTML, but, most significantly, a web page created in XML can be queried as if it were a database. The XML Query working group is providing flexible query facilities to extract data from real and virtual documents on the Web, therefore finally providing the needed interaction between the web world and the database world. Ultimately, collections of XML files will be accessed like databases (XML



Query 2002). The software industry has already developed object classes for the construction industry. The aecXML set seems to become an alternative to the IFC, which is from 2001 also available in XML form, as ifcXML. Due to the wide use and support of XML, the XML schemes have several advantages for their implementation, which was one of the reasons for merging IFC and XML (Harrod 2002). In the framework of aecXML working groups have started to develop more specific schemes. One of them, LandXML, is related to infrastructure facilities and is standardising data structures associated with mapping, survey and civil works. Version 1.0 has been published in January 2002 (LandXML 2002).

### **Road product models**

Roads have been designed with computers since the early 60's, when IBM introduced the program package HIDES. Since then the most radical changes in the road design software were mostly influenced by the development of computer graphics, which brought road design in line with other CAD software. The design of roads is, on the other hand, much more influenced by geographical data than the design of most other construction objects; therefore road design software has often been linked with Geographical information systems (Rebolj 1993).

In the late 80's, when the idea of product models has started to develop more vividly, the efforts in standardization of product model data structures in construction were focused on buildings, not on infrastructure, which caused road design software developers to use in-house standards for data structuring. On the other hand GIS standards for data exchange have been under development in the 90's, which also had to be taken into consideration. In spite of the unclear situation about infrastructure objects some research and development has also been concentrated on road modelling.

The basis of a road product model is of no doubt the geometry, which is the basic characteristic and function of the product - the road. It is clear from the described examples that geometry is at the core of all models.

The Building and Construction Research group in the Netherlands (TNO Institute) has developed a model for the description of road geometry (The Road Shape Model Kernel – RSMK), which serves as the basis for more profound description of a road (Willems 1996). The model is developed in accordance to the STEP standard. The initial anchorage and the horizontal axis elements, which are longitudinally stretched along the axis and parametrically and functionally described, define the horizontal axis. All the intermittent coordinates of points can be indirectly calculated. In this manner the quantity of data and consequently the complexity of a model are significantly reduced. The problem however arises when dealing with longer sections of a road where the summation of arithmetical errors can cause larger deviations. The authors were aware of this problem. Nevertheless, the tests have revealed that if the data is sufficiently accurately stored, the deviations are not significant. Yet, the model does not follow the way roads are being designed and it has not been reported about further development or implementation of the model.

Another model related to roads was initiated within the OKSTRA (Objektkatalog für Straßen- und Verkerswesen) project (OKSTRA 2002), coordinated by the German federal institute of roads (Bundesanstalt für Straßenwesen). The main objective of the project was to create the common platform for describing, storing and exchanging all data related to road design, road maintenance, and traffic. The authors considered the international standards, German particularities, regulations and the needs of their construction industry and traffic professionals. OKSTRA is a complex network of objects, described by using NIAM, EXPRESS and SQL, and is being accepted by the German industry recently.

The EuroSTEP company has developed a road product model for the Swedish National Road Administration. References clearly show that the geometrical part of the model is described according to STEP standard and refers to its integrated sources (Wenzel 1995). This model is the most comprehensive one and incorporates the largest amount of road data. It supports the description of the geometry, the functional classification of road elements, the determination of properties for physical objects, recording of events during the execution of a project and the geographic description of an object. By following the few publications the evolution of the model seems to have given foundations and has merged with IFC (release 3, CI-1 Road and Rail Design).

Between 1993 and 1998 a road model has been developed by the authors with the main objective to enable effective integration of computer supported processes in the lifecycle of a road, especially the

early planning phases, the geometrical design and design evaluation. The road body model (called MCT) has been derived from the geometric design data. The model was open and enabled gradual adding of elements, which were needed in other phases of the life cycle. The fundamental structure of the model, which originated from the conventional process of road design, has been preserved to achieve optimum compatibility with the prevalent software and design procedures.

The external presentation of the MCT, the road body metafile (mCT), has been defined to support the linking of the existing software, which has been used in the road lifecycle. The first step in our approach was the development of a simple metafile, followed by a rapid implementation of read / write interfaces. The interfaces could transfer suitable data to and from software packages used throughout the industry. One of the first programs equipped with the mCT interface was Plateia, a CAD program for road design. To demonstrate the use of MCT and to fill some of the “automation holes” an integrated software Environment for road lifecycle support, (called RO), has been implemented. It included functional modules in form of servers, like: Initial road corridor definition, Land acquisition support, Hazardous emissions calculation, and fast 3D visualization.

The model demonstrated many advantages and savings. However, due to the vast number of enterprises included in the process of road building, which were using much different software, and were not interested in exchanging data, it was not brought to real life. Also, we had received some criticism concerning the simplicity of the model. It was, however, already evident after many experiments in product modelling in construction that complex models introduce many obstacles to dissemination, and that the high functional efficiency of the MCT model proved that preserving simplicity is a good paradigm. Therefore we continued with improvement and upgrading of the model and with testing of different product modelling standards. (The MCT evolution can be followed in Rebolj 1995, 1996, 1997, 1998, and 1999.)

The following disadvantages of the MCT model were summarized:

- There is only one axis, which is actually the only longitudinally defined element (in a ground plan). All other elements are defined only in cross-sections.
- Cross-section elements do not have a unique identity and therefore cannot be unambiguously bound together along the axis.
- Cross-section elements are too “rough” – dataset structure is too simplified (poly-line).
- In the “STEP version” STEP standard is used only for the recording of data. There is no standard scheme for the road description – therefore the data cannot be exchanged if the relevant programs are not previously adapted.
- The MCT describes only the road body; despite that the model is open also for other elements or views, which has been proven with upgrading the model with data on building materials (Hanžič 2000).
- The comparison with the models based upon the geometrical description in the functional form of the 3D geometrical bodies (e.g. RSMK) shows, that the MCT is too rigid in the 3D representation. Namely, the 3D representation depends on the position of profiles, which does not assure the homogeneity of the description (its totality and independency).

The above disadvantages led to a new – improved concept of the MCT (the road body model), which also got a new name - the road product model or PMC.

### **The PMC road product model**

In essence, the PMC is still based upon the conventional road design – the axis projections, cross-sections and cross-section elements. These fundamentals have been preserved mainly due to the compatibility with the current design practice, methods and tools.

The objectives of the improvements and the upgrade from the MCT to the PMC are the following:

- To create an object model, which links together the classical projections of road elements into 3D space-integrated objects; elements of the PMC on a higher abstraction level (axis, carriageway, retaining wall, pavement, etc.).
- More consistent, accurate and effective object structure of particular road elements.

- Heterogeneous-environment support. The implementation of a model with widely accepted technologies, which would enable a successful transfer into practice.

The presented model describes a single section of a road. In a broader view, a road is a combination of road sections, and in turn a set of roads builds a road network. Every road section is embedded in a geometrical space that is defined as a cluster of 3D objects, bound to the terrain model. A particular section is created and changed as a result of a building or a maintenance project.

The structure of the model and the implementation approach of the PMC by using XML elements are described in the following sections.

#### *The PMC Architecture*

While re-designing the architecture of the road product model the intention was to create a structure, which would enable a view of data on a high level of abstraction. Therefore, the concept of *road objects* was incorporated into the model, which is not usual for a road model based on conventional road design. A road object, or object for simple, is here viewed as a part of a road body, which can be found in the real space. The software developers, by using the PMC model, have the possibility to manipulate whole objects, access particular data through the object they work with, or to have a direct access to data on the level of basic elements.

The fundamental structure upon which the abstract objects are implemented is constituted by basic elements of the conventional road design. The structure is linking the following projection layers: ground plan, side view of the axis, and arbitrary planes, which are perpendicular to the axis (cross-sections). The objects are actually aggregations of particular elements defined through basic geometrical primitives. Hence, geometrical characteristics represent the essential origin to which other attributes of the object are bound.

The ground plan projection of road objects is represented by *ground-plan objects*; a ground plan is thus a set of ground plan objects (Figure 1), which uniquely belong to road objects.

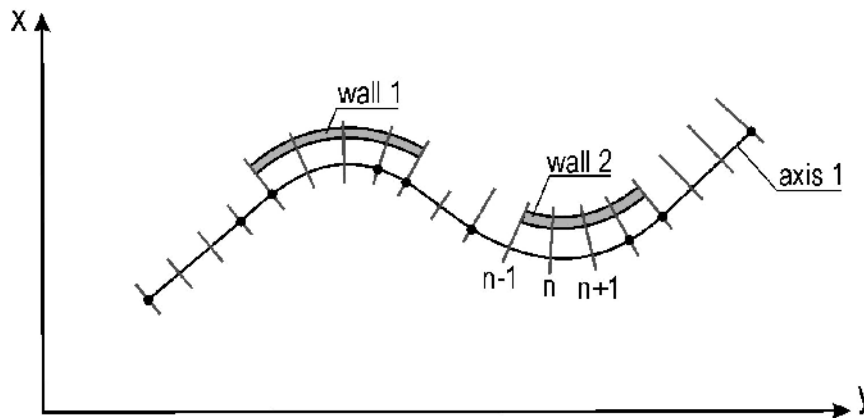

Figure 1. Ground-plan objects - road objects in ground plan projection.

The cross-section projections of objects are represented by *cross-section object*; a cross section is a set of cross-section objects, which are either bound to a particular axis (which means they “move” with the axis) or not (see Figure 2). Each cross-section object uniquely belongs to a road object. The possibility to unbound cross-section objects from an axis enables incorporation of objects that are not axis-dependable, but should be included in the model (e.g. the ones that already existed in real space). Most cross-section objects are, however bound to an axis, since they belong to the road body. All road objects can also be viewed in a side plan, which is primarily intended for the definition of road axis parameters (long profile), or for the input of elevation coordinates of objects.

The methods (program functions) of the road objects should enable the determination and modifications of their geometrical characteristics in any chosen projection. The projections are, actually, only specific geometrical representations of road objects; therefore the alterations of projected road objects in one projection (appearing as ground-plan objects, cross-section objects, or side-plan objects) affect the road objects, and all other projections consecutively. This principle is assured “by structure”, not “by

function”. The connections between cross-section objects, which shape each road object (see “wall 2” on Figure 2), can be defined as either linear or parallel to an axis, to which they are bound.

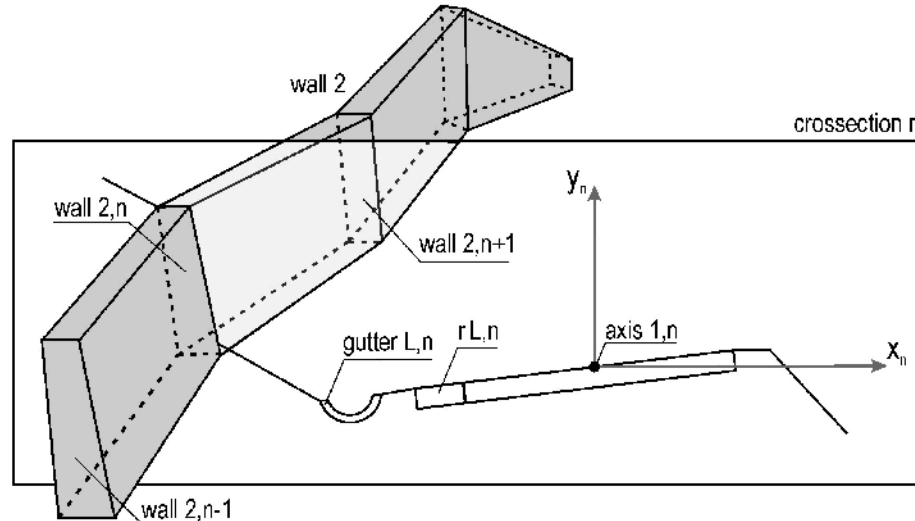

Figure 2 Cross-section objects in a single cross-section, and a road object, defined as a collection of consecutive cross-section objects.

The following figure shows the class diagram, which represents the essential structure of the PMC model (grey parts on Figure 3). The *Section geometry* class links other elements of a given section. The basic elements that constitute the geometry are the road *axis* and the *cross-sections*. The cross-sections are bound to the road through the cross-section points (*StationaryP*). Normally the cross-sections appear in regular intervals or at optional points on the axis where road objects have to be changed (e.g. a new object begins, a wall dimensions change, a gutter ends, etc.). Another important element in the model is the *road object*. It represents an actual road object in the space (carriageway, retaining wall, gutter, etc.). Road objects are parts of the road section, and are globally geometrically determined with a sequence of cross-section objects, which are linked to the road axis through cross-sections.

#### Implementation of the PMC

In the past, we've used in-house format to describe the structure and the data of the road model. The external description was a simple ASCII file with a predefined structure of sections. With such a representation we encountered many problems because of a lack of universal reading tools. Later, we described our model with the STEP standard constructs. During a PMC development stage XML took a major role in the field of data transfer and exchange. It brought a standard medium for data recording and presentation. A significant advantage of the XML language is the existence of standard tools for parsing, reading, and querying XML documents. These tools simplify the development of application interfaces. From our past experience we can say that successful transfer of the model to a business process highly depends on such IT infrastructure.

The second problem of product models is compatibility of their data structures with related models and tools that support an application domain. We already presented several product model initiatives in the field of road construction above. All of them define their own basic elements and structures. From these examples we saw that primitive structures are very similar. It would be uneconomical and it would also increase the complexity if new elements would be developed. Therefore we decided to use primitive elements of one of the existing models. All known road product models are describing road geometry using one of two basic principles – indirectly with functional description or directly with space coordinates. Since our PMC structure is based upon geometric objects, we searched among models that describe geometry with polygons in 3D space. The final decision was to use LandXML structures (LandXML 2002).

As the PMC class diagram presents, all main elements of the road geometry are derived from existing classes defined with the LandXML model (Figure 3). Objects from PMC model can be recorded to XML

document with direct use of LandXML schemes. Road section geometry is implemented as root LandXML class, axes are implemented with the Alignments class, cross-sections as CrossSect class and cross-section objects as CrossSectSurf class. We extended the LandXML structure with the road objects, which are unique to the PMC model.

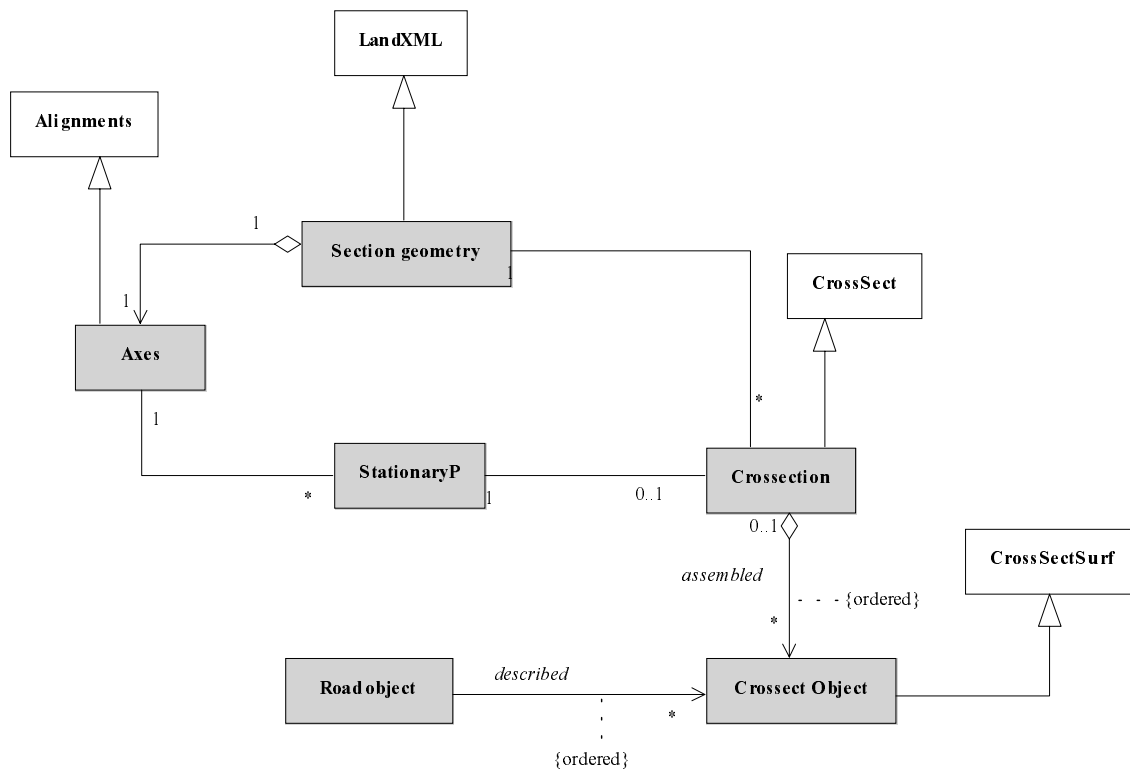

Figure 3. PMC class diagram (grey), with LandXML classes (white).

The selected approach allows reading, parsing and interpreting the basic structure of PMC documents with tools from independent developers. Unfortunately the version 1.0 of the LandXML was just introduced (31.1.2002); therefore such tools don't exist yet, so we had to develop an API library that supports the presented object model. On the other hand some parts of the API will always be needed for accessing the data on higher abstraction level of road objects and exploitation of all capabilities of the PMC model. Except if road objects would be included in some later version of LandXML scheme, which would actually mean that the models would merge - a common practice in the present stage of the evolution of product models. LandXML on the other hand includes many elements, which are not appearing in PMC, but would be useful in, for example, traffic analysis. Merging is therefore even more reasonable. Hereby it is again possible, that the complexity level of LandXML could exceed the manageable boundaries.

A few applications already use the PMC/landXML model. In a test conducted in May 2002 in a design company Lineal the following phases were successfully linked by using the integrated data in the PMC road product model: geometry design with Plateia (an AutoCAD based product of CGS), 2D view (in a GIS environment), 3D view, and Land acquisition (Figure 4). A much higher degree of interoperability is expected when more software will be able to parse and interpret, in its own way, the landXML structures.

### Lessons learned

Our experience with road product model transfer from academy to praxis in previous iterations, guided us in our work in particular. It was proven that introduction of the model to a business process is a highly complex task that demands well defined goals and a smooth transition. Our goals were twofold. First, the model should provide data access on a high level of abstraction – on the level of road objects, which can be accessed in a simple way. On the other hand, the model should be implemented and supported with a

clear technology that is broadly accepted in the user community and not too complicated for implementation. We think XML is a part of such technology.

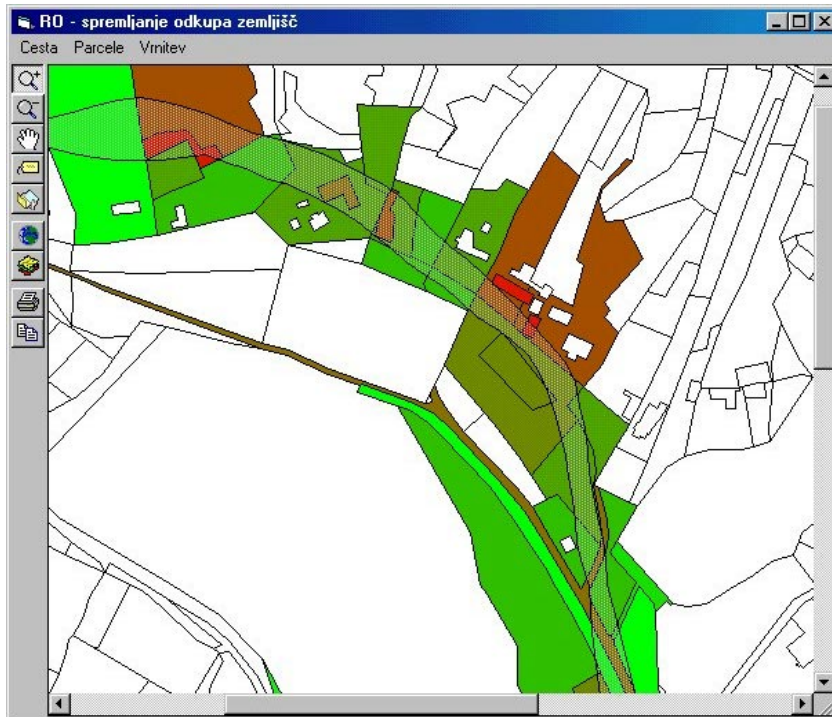

Figure 4. A GIS application to support land acquisition process; the road boundary, read directly from the PMC model, is seen covering parcels in a transparent colour.

Maybe the most important finding was that the idea of a total product model, which would incorporate all possible views, is senseless, probably even impossible. A (kind of) total product model should rather look like a network of manageable particles, without permanent binding, with “roles” assigned in the moment of integration. We think that models with a huge number of predefined connections, with other words, with a very high level of complexity, are too expensive for use. Therefore we don’t look with much optimism on highly complex models, and actually don’t see a solution in the trend of expanding and merging of models.

On the other hand, manageable middle-size models cause another problem, because it becomes necessary to interconnect them for different user needs. The final structure of such interconnected model is defined by the environment of the target model application. The model can be assembled from parts that originate from different models, which are dispersed in a distributed environment. For the integrated behaviour, “understanding” of the parts, the translation among them, and the communication and harmonisation, we introduced the principle of the Virtual product model (Rebolj and Tibaut 2000). In this way we might approach, or include, the self-organisation principle in the future evolution.

## Conclusion

In this paper, evolution of a road product model, developed by the Construction IT Centre at the University of Maribor is described. The last modification of the model, called PMC, is presented in particular. The path we were going could shortly be described as “From simple to complex and back again”, whereby experiences and new findings have formed the evolution to be a spiral rather than a circle, and the “simple again” is only true if seeing the model in isolation. It should, however, be a part of a network of simple pieces, following the statement of the physicist Fritjof Capra, who wrote “In the new systems thinking, the metaphor of knowledge as a building is being replaced by that of the network. As we perceive reality as a network of relationships, our descriptions, too, form an interconnected network of concepts and models in which there are no foundations.” (Capra, 1996)

## Literature

1. Björk B.C. Basic structure of a proposed building product model, *Computer Aided Design*, 21(2), pp. 71-78, 1989.
2. Eastman C., Augenbroe F. Product modelling strategies for today and the future, *Proceedings of the CIB W78 conference The life-cycle of construction IT innovations*, The Royal Institute of Technology, Stockholm, Sweden, pp. 191-208, 1998.
3. Turk Z. Constraints of product modelling approach in building, *Proceedings of the 8th International conference on Durability of Building Materials and Components*, NRC Research Press, Vancouver, Canada, pp. 2776-2787, 1999.
4. Rebolj, D. and Tibaut, A. Virtual product model : a concept for better information management processes, *Third European Conference on Product and Process Modelling in the Building and Related Industries ECPPM*, Lisbon, Portugal, 2000
5. IAI, [http://www.iai-international.org/iai\\_international/](http://www.iai-international.org/iai_international/), last accessed April 2002.
6. Harrod, G. aecXML & IFC, <http://www.cadinfo.net/editorial/aecxml.htm>, last accessed April 2002.
7. XML Query: <http://www.w3.org/XML/Query>, last accessed April 2002.
8. LandXML: <http://www.landxml.org/>, last accessed April 2002.
9. Rebolj, D. *Computerunterstützter integrierter Straßenentwurf in einer objektorientierten Umgebung*. Graz: dbv - Verlag für die Technische Universität Graz, 1993.
10. Willems, P. H.: *TNO rapport – Documentatie WegGeometrieModel*, TNO, Rijswijk, 1996
11. Willems, P. *Road Shape Modeller. Product modelling demonstration CD-ROM*. TNO Building and construction research, Delft, 1996.
12. OKSTRA, *Objektkatalog für das Straßen- und Verkehrswesen*: <http://www.okstra.de/>, last accessed April 2002.
13. Wenzel, B. G.: *The Road Product Model of the Swedish National Road Administration*, EuroSTEP, 1995.
14. Rebolj, D. *Integrated road design and evaluation environment. Computing in civil and building engineering*. A. A. Balkema, Rotterdam, 1995, pp. II/1001-1006.
15. Rebolj, D. *Integrated information system supporting road design, evaluation, and construction. Computing & information technology for architecture, engineering & construction*. CI-Premier, Singapore, 1996, pp. 281-288.
16. Rebolj, D. *A product model of a road. IKM - Internationales Kolloquium über Anwendungen der Informatik und Mathematik in Architektur und Bauwesen*. Bauhaus - Universität Weimar, Weimar, 1997, digital proceedings on CD-ROM.
17. Rebolj, D. *Integrated information system supporting road design, evaluation, and construction. Journal of Microcomputers in civil engineering*, 13, pp. 179-187, 1998.
18. Rebolj, D. *Integration of computer supported processes in road life cycle, Journal of transportation engineering*, 125(1), pp. 39-45, 1999.
19. Hanžič, L. *Celostno modeliranje podatkov o materialih zgornjega ustroja ceste*. Masters Thesis, University of Maribor, Maribor, 2000.
20. Capra, F. *The web of life: a new scientific understanding of living systems*. First Anchor Books, New York, 1996.