

INFORMATION TECHNOLOGY IN THE STRATEGY OF A MIDDLE-SIZED CONSTRUCTION COMPANY

IT in middle sized construction company

S.F. SLAVENBURG and T. M. H. VAN STRATEN

Slavenburg's Bouwbedrijven B.V., Schiedam, The Netherlands

Durability of Building Materials and Components 8. (1999) *Edited by M.A. Lacasse and D.J. Vanier.* Institute for Research in Construction, Ottawa ON, K1A 0R6, Canada, pp. 2370-2376.

© National Research Council Canada 1999

Abstract

This paper presents how Slavenburg's Bouwbedrijven B.V. uses IT in their Design/Build concept. This concept necessitates a migration in culture: moving from being a component in a production process, towards offering a total product. The paper presents experiential knowledge gained from implementing sophisticated computer tools, applications and networks in a middle-sized construction company. Some practical views of IT implementation are presented and discussed, including the selection of hardware platform, software suites, and applications. The advantages of centralised services are also discussed. In summary, the use of IT has provided new opportunities for the company and has helped the company's migration to Design/Build.

Keywords: Design/Build, data exchange, standards, workflow, enterprise resource planning, knowledge bank, document management

1 Introduction

Slavenburg's Bouwbedrijven B.V. operates throughout The Netherlands as a construction and development company and it is excessively specialised in offices and commercial real estate (Slavenburg 1999). The turnover in 1999 will be approximately 200 million Dutch guilders, or \$100 million US.

Traditionally a midsize construction company is one of the participants in the chain between the project development and the facility management of real estate. As Slavenburg's Bouwbedrijven B.V. wants to become a leading Design/Build company in The Netherlands, and as such the only responsible partner dealing with the client; therefore close teamwork with other business partners of different disciplines will be necessary. There are several ways in which information technologies (IT) can help to achieve this strategy:



- Within the relation “costs / usefulness”, using IT where possible.
- Improving the quality of the employees within the total context of Design/Build.
- Simplifying the primary process through:
 - Workflow management, especially document management and improving data information communication between the design partner and the next players.
 - Improved communication using modern technical tools.

1.1 The company organisation

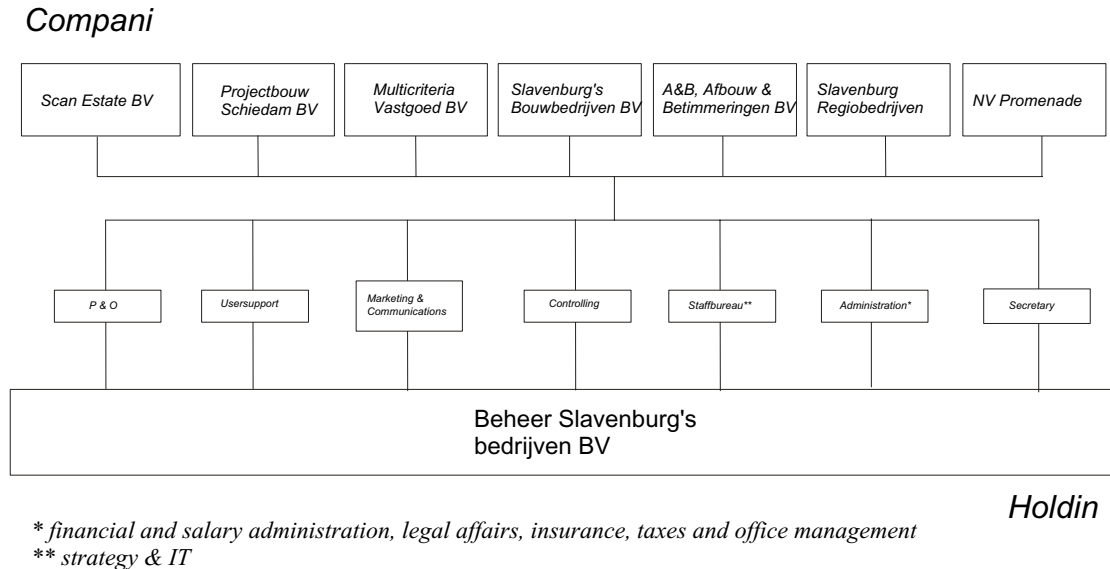

Fig. 1: The position of Slavenburg’s Bouwbedrijven B.V. in the holding

Disciplines such as IT & Strategy, Human Resource Management, Office Management and Administration are centralised for the company. The companies, identified in Figure 1, are located in three cities in The Netherlands: Schiedam, Leerdam and Dordrecht. The companies have an average of 35 building projects at any given time. The company employs approximately 250 people, and augments their work with labour provided by subcontractors.

2 Design/Build: the idea

Design/Build means the complete integration between those two disciplines; as the construction company is a single point of responsibility for the entire process, it’s important to communicate well with the architect.

To promote the idea of Design/Build, it is essential to know in advance “what are the needs and expectations of the client?” In the initial contact with a prospective client, Slavenburg’s Bouwbedrijven B.V. uses a checklist, based on interviews with previous clients. Together Slavenburg’s Bouwbedrijven B.V. and the prospective client fill in the detailed items, as well as functional requirements.

The final product of this stage, as the company sees it, should be an accumulation of a company's standard elements, based on experience, functional requirements, modern materials and techniques, etc. Each element on this accumulation is then classified in terms of comfort, quality and price. Together with accessories and material alternatives, these elements form the foundation on which the client makes choices and on which the architect assembles the design.

3 Choices in IT

To use IT in the chain from concept, design and construction through to maintenance, as well as to be responsible for the necessary information exchange, the first step is to have a solid information process supported by a reliable IT system within Slavenburg's Bouwbedrijven B.V.. In 1995, the company adapted a Total Quality Management (TQM) model and began to implement a strategy to replace our entire IT system: platform, operating system, infrastructure, hardware and software.

As Slavenburg's Bouwbedrijven B.V. is a contractor itself, being the only responsible partner dealing with the client, the company prefers to work with as few IT partners as possible. In order to be able to connect and to maintain the data exchange between new and changing partners in the future, the company is on the "lookout" for industry standards.

3.1 Information process

To build a solid information chain, a construction company needs both a solid organisation and series of processes. The information process runs parallel to the production process: both the primary processes and the secondary processes. To control the workflow, one must first integrate TQM with the organisation's logistic- and document management software. The second step is to put a shell of workflow management software around it and then you can implement top-down management information software.

3.2 Platform, operating system, infrastructure and hardware

Though Slavenburg's Bouwbedrijven B.V. was aware of the difficulties in maintenance, the company chose a client/server environment with a Windows NT Server as the operating system software. Scalability, integration and connectivity were the keywords for this decision. In a later stage, the company will want to fit in network computers as well. The company is now migrating from Windows 95 towards Windows NT Workgroup on the client workstations. The system configuration is presented in Figure 2. The LAN uses UTP category 5 with the speed of 10 Mb/s. If necessary this speed can be increased to 100 Mb/s. Data exchange between the company's three locations communicates by a 64 Kb/s connection with an ISDN-2 line as a backbone. Servers, workstations and portable computers are easy to reconfigure and are purchased from the same vendor, in order to reduce potential hardware and software conflicts.

3.3 Software

In the company's experience, the integration of several software packages is best done by using one database; in which all data, used by all the specific disciplines of a construction company, is only once and uniquely stored. Because the previous mini-computer system had reached its capacity in 1995, the company started the system replacement with new office management software first. Already using a number of Microsoft products, the choice for an office suite was not very difficult: namely, Microsoft Office. At that time the company could not find standard document management software. So a Microsoft Solution Provider built a customised system for the company, using FoxPro tables in a project-wise document storage system. It was given the name *Stonebuilder*. Our organisation did not buy a relational database at that time, because it was hoped that our logistic software would provide us with one in the future. To fill in the logistic part we looked for Enterprise Resource Planning (ERP) software supporting specific disciplines of a construction company. Our company finally selected the Baan business-model for the building industry. Most of the implementation of this software will be completed by the end of 1998. Workflow Management- and Management Information software are planned in future expansions.

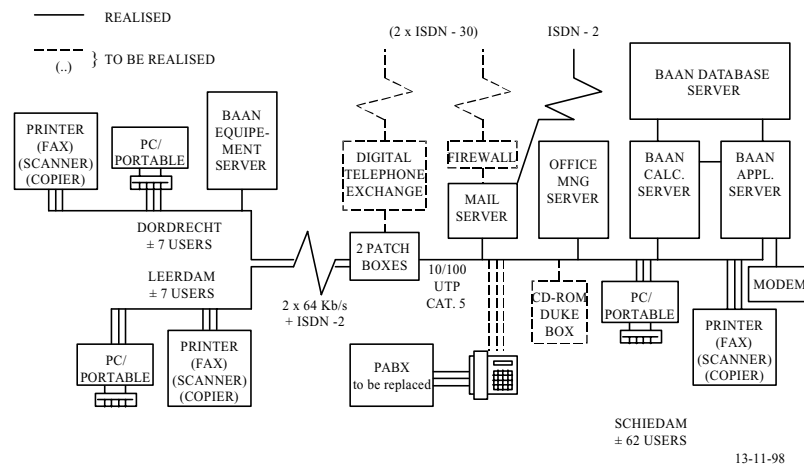

Fig. 2: Configuration Beheer Slavenburg's Bedrijven B.V

4 Design/Build: the realisation

The benefits of working with a totally new concept, such as Design/Build can be found in a number of areas: (1) clearing up bottlenecks, (2) improving procedures in the traditional way of designing and constructing processes, and (3) being creative by using modern knowledge and techniques. This paper discusses our achievements to date, as well as, Slavenburg's Bouwbedrijven B.V. current the action plan.

Table 1: User Software for domain disciplines

DISCIPLINE	SOFTWARE
Relation management	Baan IV
Graphic design	Corel Draw
Design	AutoCAD 14
Estimating	Baan IV
Project engineering	Baan IV
Execution	Baan IV
Project control	Baan IV
Invoicing	Baan IV
Purchasing	Baan IV
Accounting	Baan IV
Equipment control	Baan IV
Salary administration	CTB
Planning	Power Project
Office management + E-mail	Microsoft Office 97, Exchange Server, Proxy Server
Document management	Stonebuilder
Building maintenance	Spectrum
Facility management	-
Human resource management	Exact
Workflow management	-
Construction site	-

4.1 Human resources

In migrating a company from a more-or-less traditional culture to an innovating one, it is necessary to train the employees, to upgrade their skills, and to support them with up-to-date knowledge and documentation. In 1996, all our employees with a management function were trained to deal with changes. For example, in our Schiedam location, we have a centralised and up-to-date documentation centre, also using CD-ROMs. Effective March 1999, the company starts implementing a knowledge bank, using a full-text search engine on an Intranet and the Internet.

The increasing need for information, mostly fed by our own management and by government regulations, is due to the fact that more specific input data is required. During the construction, the construction site is the source of most of this input data. The skills of our site-managers are more practically based; and the site-manager is not an administrator. Therefore in April 1999, the company will implement specific IT-tools on the construction site, as a part of the Baan ERP software. The main intentions are to drive back most of the administrative handling; that is, data pertaining to the project, that is already in the our database, will be transferred to the construction site, so the site-manager only has to fill in the missing parts instead of filling out blank forms each week. This will also create a virtual entrance to the digital part of our documentation centre and our knowledge bank.

4.2 Communication

Attending meetings away from one's own office entails considerable time and travel costs.. In a small country such as The Netherlands, or in any large metropolitan area for that matter, there is considerable traffic, and therefore travel inefficiencies. Using techniques as E-mail, remote access, Intranet newsgroups, videoconferencing and an interactive web site can reduce these inefficient costs. The client as well as the project-manager or the architect will be able to communicate with each other at any time and with up-to-date information from a number of different sources:

- Logistic (Baan) database;
- Document database;
- Planning;
- Document centre;
- Knowledge bank.

Working with these shared resources and tools, it is necessary to protect information in such a way that employees can only delete, create, copy or read that information to which they are entitled . It also asks for a 'waterproof' office-, mail- and document management system:

- in order to deal with valid and up-to-date document versions;
- with central access of unique documents to avoid the creation of an E-mail copy-culture.

At the current time, the company is again looking for standard software which will fill this requirement so a pilot project can be started to realise our ideas and achieve our aims.

When our construction site automation has been successfully implemented, the company will start Electronic Data Interchange (EDI) with our suppliers and sub-contractors, using the same communication- and firewall tools.

4.3 CAD

The easier way to use data from the design partners in the rest of the chain, described earlier, is to work with compatible software. For the architect in the Slavenburg's Bouwbedrijven B.V. Design/Build product, the design should be completed using standard layers in AutoCAD. Unfortunately most architects prefers working with specific building-design CAD software in place of AutoCAD. There are three arguments why the architect is against this kind of co-operation:

- Specific building-design CAD software is cheaper, because the user only needs buy one CAD software package instead of AutoCAD, in addition to specific building-design CAD application software;
- The architect can design faster with specific building-design CAD software (as fast as the manual colleague);
- In The Netherlands, an architect takes no responsibility on the exactness of the measures in drawings.

Most of the architects use standard CAD elements with which they put together their design.

Loyal at its Design/Build principles, Slavenburg's Bouwbedrijven B.V. started with creating its own standard elements in 1998. These elements were created in a specific building-design CAD application, are standard-layered, are AutoCAD based and are ready for 3D presentation. Taking full responsibility on the measures, the company engaged architects who want to use these elements in their designs, as soon as Slavenburg's Bouwbedrijven B.V. can provide them and, if necessary, the appropriate software. In the year 2000, the company expects to be able to use electronic design-data in the rest of the chain.

5 Conclusion

As the reader can see, even though an IT strategy can be formulated on paper, the difficulty is locating industry software standards and other communication tools, which can fill in the desired functionality and can integrate with each other. Slavenburg's Bouwbedrijven B.V. is now a contractor in on the European project: *Future Home* (1999) within this international context, working with a mixed team, the company expects to find new and innovative ways and possibilities, such as Virtual Reality (VR), to use IT in improving our Design/Build concept.

6 References

Futurehome (1999) forth.cv.ic.ac.uk/futurehome/Welcome.html, April.
Slavenburg (1999) www.slavenburg.nl (in Dutch only, April).