

# INFORMATION TRANSFER IN THE STRUCTURAL STEEL CONSTRUCTION PROCESS

Lars Sanne, M.Sc.(Eng.), Ph.D. candidate  
Dept. of Structural Engineering  
Royal Institute of Technology  
Stockholm, Sweden  
e-mail: larsan@ce.kth.se

Ulf Keijer, Assoc. Professor  
Dept. of Structural Engineering  
Royal Institute of Technology  
Stockholm, Sweden  
e-mail: ulfkei@ce.kth.se

## Abstract

*The prerequisites for the information transfer in a fragmented building process and, in particular, the structural steel construction process is discussed. The importance of deep understanding of the real construction process prior to the development of the information transfer systems for the construction process is emphasised.*

*Monitored seminars, utilising so called group dynamic modelling technique, have been carried out in order to increase the understanding of what information is managed and transferred in real construction processes and why the process functions as it does, today.*

*A tentative formal information transfer model is proposed, based on a basic information transfer model, the triple role concept, and the theory of axiomatic design.*

## 1 THE STRUCTURAL STEEL CONSTRUCTION PROCESS

### 1.1 A SUBPROCESS OF A COMPLEX SYSTEM

Steel utilised as the principal material for the load-carrying and stabilising elements is commonplace world-wide. In Sweden, however, concrete has had a very strong position as structural construction material, traditionally, also depending on the fact that demand for high-rise buildings for various reasons has been weak. In spite of this, steel has gained increased interest as material for structural systems during the last 15 years. Light weight, fast erection and flexibility are the predominant advantageous factors.

The structural system represents a small part of the total effort in obtaining a building. Nevertheless, the structural system constitutes important properties both of the building itself, and of the process for its achievement. It provides shape, safety and defines the possibility of attaching secondary functions, like cladding, mechanical systems, *etc.*, to it. Further, for the process, the erection of the



structural system visualises the total size of the building and makes more concrete the total work to be done for all parties involved. Apart from the foundation for the structure, the structural system is also an early task of the construction work. Faults or delays in this part of the process will influence the following work to a large extent.

The building process encompasses a number of stages [e.g. Keijer 1993], the principle of which are the clients brief, planning, design, construction planning, construction and operation. The same phases are performed for the different principle requirements of the building, e.g. the structural system, the energy system, mechanical systems of different kinds, as well as pure architectural considerations like the internal transportation system and aesthetic issues, on a sublevel. These different subprocesses are intertwined, partly dependent, partly independent of each other.

In general, a large number of different and basically unlinked actors are engaged in a specific building project. These actors have not co-operated in the same roles previously, generally. The co-operation is based on specifying contracts, presumed ability to fulfil contracted undertakings both technically and financially, liability for non-performing, and economic (counter)measures, i.e. compensations, delayed or reduced payment, damages and suchlike. Theoretically and also in practice, a specific actor, i.e. a consultant, a subcontractor, or a supplier, is regarded to be replaceable similar to a plug-in/plug-out-system. The system as a whole is based on a view that each actor optimises his own activity under the presumption that he is aware of the overall requirements of the enterprise. The latter is not too often the case. A heavy burden is then placed on the planning and the management of the project. As Arthur Koestler has pointed out [Koestler,1978,p.50 *inter alia*] the objects in one hierarchy may belong to other hierarchies where the hierarchical orders may be very different. If applied to the actors of a building process this means that the importance and the relative position of a specific actor in the process may be regarded differently from, e.g., the project management on one hand and the actor itself on the other hand.

Checkland [Checkland,1986,p.110] distinguishes between four general types of systems, i.e. *natural systems*, *designed physical systems* (e.g. a building), *designed abstract systems* (e.g. a design method, a product modelling schema), and *human activity systems*. Checkland emphasises the difference between the three former types of systems in relation to the fourth, the human activity system. In the latter case, the system is not independent of the viewer/user of the system. Its performance is dependent on the actors, who in this case are *parts of the system itself*. When studying the building process, or a part of it, this fact must be recognised and given appropriate attention. Emerging approaches acknowledging the character of human activity complex systems, also known as *dynamic complex systems*, may be crucially useful for the development of the understanding how to build information systems supporting such dynamic processes, [Freedman,1992], [Waldrop,1992], [Senge,1993]. These approaches may be equally fruitful for the modelling of the information transfer of the building process.

## 1.2 A GENERAL OBSERVATION

The building process very often is seen as a self-contained activity, with a specific start and finish. Efficiency, quality, management, organisation, *etc.*, all elements of the building process in different hierarchies, are related to the very process itself, when studying it explicitly. Quality, *e.g.*, according to ISO 9000 standard, is seen as subjective property in a given case, *i.e.* the fulfilment of client's need. In practice it often turns out differently. Client's need is interpreted so as to conform to a specific standard, practice or rule, in principle defined by the construction profession, neither by the client nor by the final user of the building.

In real life, the building process, BP, is seldom primary. It is caused by some other process, which could be called *the governing process*, GP, let it be a industrial business process or people's moving to a new home, see figure 1.

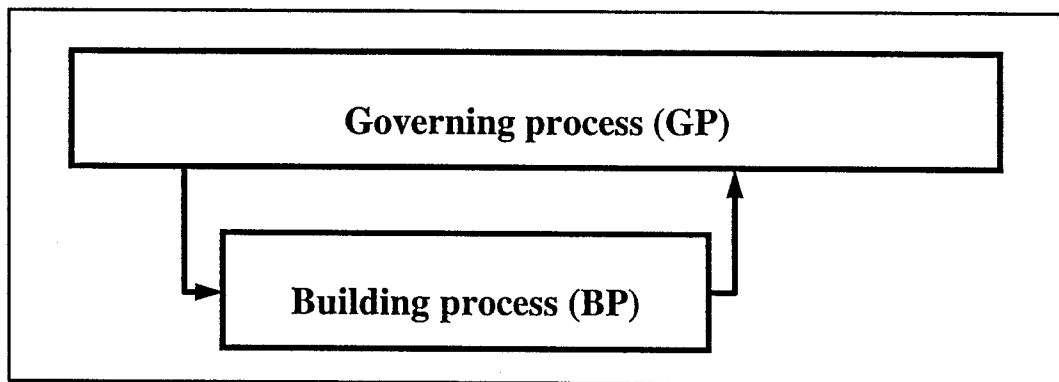

Figure 1. *The building process, BP, a secondary process, supporting some other governing process (GP).*

As a consequence, the basic objective of the building process should be to fulfil the requirements of the governing process, and primarily not the specifications generated within the construction community itself. A discrepancy between the formal requirements and the real demands from the GP exists in most cases; otherwise should not the overwhelming part of newly constructed buildings be taken into use by the clients, in spite of sometimes very severe violations of reasonable requirements, for example concerning HVAC-systems, noise and vibration insulation, moisture problems, *etc.* The demand on keeping the GP going is very strong in most cases. Severe, but bearable, problems encountered will be resolved later, successively, if ever.

If we allow ourselves to assume that there exists of a discrepancy between what is specified technically within the BP and what really is needed as a minimum for not fatally disturbing the GP. This existence is then a sort of tacit knowledge of the construction industry, which more or less unconsciously is utilised at bidding, design and construction planning. The general notion of lack of enough time for a complete and consistent design in order to fulfil all prescribed and otherwise conceivable requirements on the building could be referred to this observation [Sundsvik&al,1983]. It should also be noted that both the client and the contractor take part in this game. The client aims at a low price. The lowest possible price

will then include the possibility of a product which primarily satisfies those needs, and those needs only, defined by the governing process.

If the observation made above could at least partly be accepted, which of course remains to be seen, the prerequisites for a consistent and transparent information transfer between the parties of the building process is in danger. An information structure must relate to the real process, not to an assumed or desired process. These processes do not inherently comply to each other. A search for an understanding of the real building process, its prerequisites and driving forces is therefore absolute necessary so as to arrive to an appropriate information structure, that could be accepted and applied by the actors of the building process.

What is said here about the building process as a whole is equally applicable to different subprocesses. Thus, the principle observation made should be duly taken into account for the structural steel construction process, as well.

### 1.3 THE COMPONENTS OF THE STRUCTURAL STEEL CONSTRUCTION PROCESS

The structural steel construction process, SSCP, is a subtask of the building process. In its main parts it could be considered relatively independent of other tasks, provided the necessary foundation for the structure has been placed properly. Fundamental changes of the overall layout seldom occur after the design is completed, although minor alterations may take place. Change of load specifications is more frequent. Minor adaptations to the piping and other mechanical systems in later stages of the construction phase are commonplace. A typical structure is outlined in figure 2.

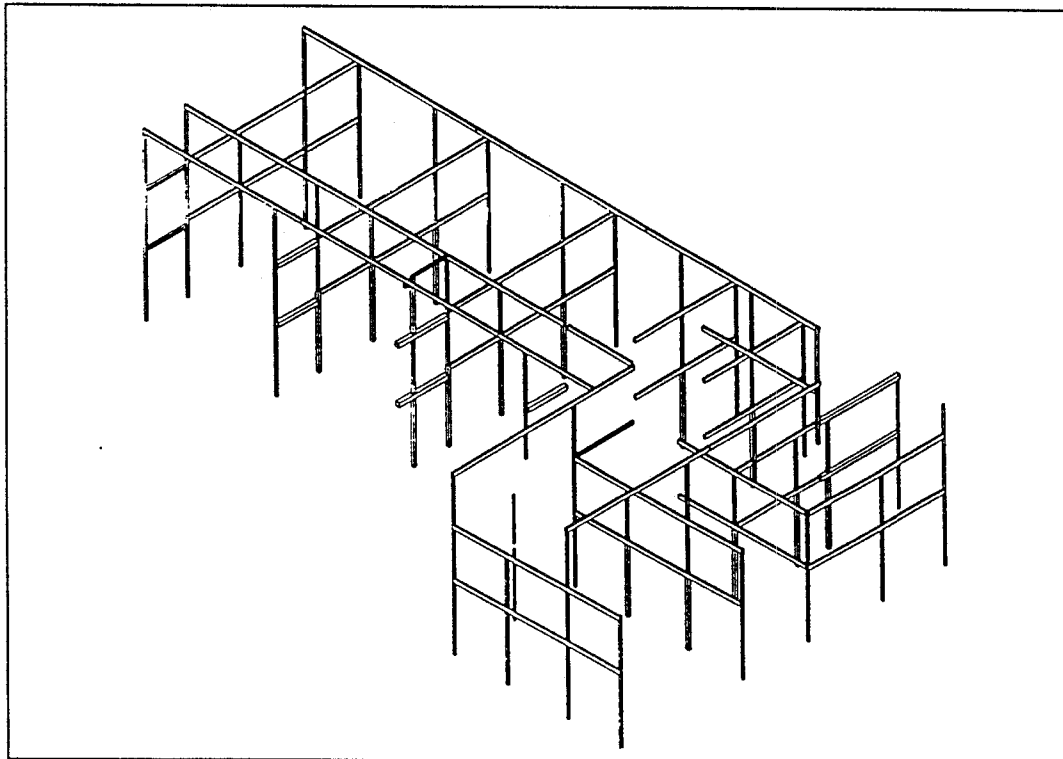

*Figure 2. A two-story steel frame - a typical object of the present study.*

The main parts of the SSCP are similar to those of the general building process, *i.e. planning, design, manufacturing and erection* on site, see also figure 3. These steps are generally considered to be consecutive, although iterations take place on lower levels of the process. The design may also be repeated as a part of the manufacturing. The same designer is not necessarily engaged the second time. Different teams manufacture the steel members and construct on site, in general. Typical actors of the process are the architect, the structural designer, the general contractor, the steel manufacturing shop and the steel construction company on site as a subcontractor.

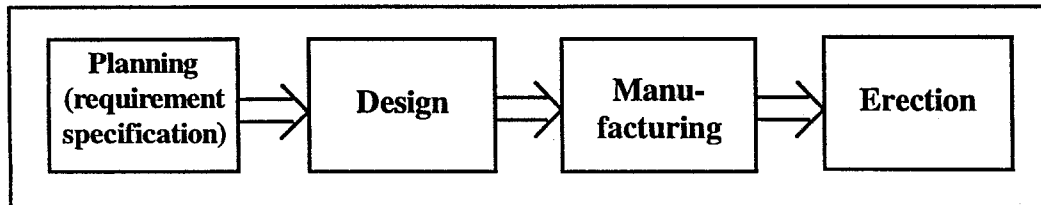

Figure 3. Components of the structural steel construction process.

## 2 INFORMATION TRANSFER

### 2.1 GENERAL

Information transfer between two bodies, let it be individuals or systems, can only take place if a number of conditions are satisfied. Figure 4 depicts a chain of links and transformations necessary for having a piece of knowledge, view or information transferred. Agreed protocols are necessary on at least two levels, on the physical level and on a semantic level. The message must be able to be conveyed technically, but also possible to formulate so as to be interpreted by the receiving body.

To have the transferred information transformed into working knowledge, to be actively used by the receiving part of the chain, another condition must be met. The interpreted information must be *incorporated* into the mind of the receiver. This puts requirements on previous knowledge and the structure of this knowledge of the receiving individual. Previous experience of similar contexts in which the message is received is in general advantageous, albeit the opposite may be the case, *e.g.* when non-traditional or novel procedures are to be applied. This could be referred to as *shared structure of knowledge* pertaining to the construction process. If the receiving body is an artificial information system the transferred piece of information must be able to be stored fully according to the general schema of the database in order to be found and retrieved exactly as previously stored information.

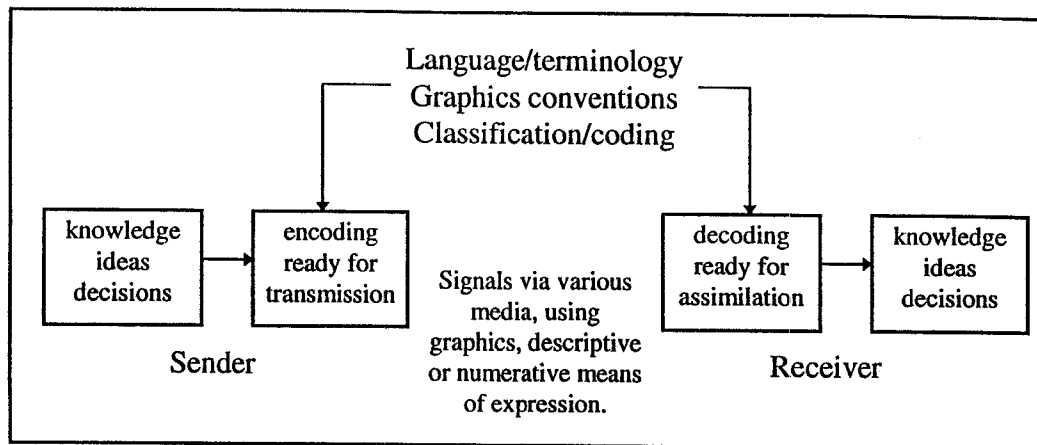

Figure 4. Elements of the information transfer process, after [ISO/TC 59, 1993].

## 2.2 MEDIA

Traditionally, the principle transfer media of the construction process has been drawings, and specifications pertaining to these drawings. The increasing application of CAD techniques has not changed this, fundamentally. Specifications including drawings still serve as formal contractual documents. Other forms of information transfer are utilised, to an increasing extent. Telephones, including cellular telephones, telefax, electronic mail, and other forms of telecom based media are most typical. CAD drawings can be remotely produced anywhere, also on site.

The above structure of the information transfer process apply for all these different communication techniques, and should be taken into account when analysing the information interchange as a part of different building processes.

## 2.3 THE IMPLICATION OF A FRAGMENTED BUILDING PROCESS

The building industry is said to be fragmented. Many actors are involved in a specific enterprise, *e.g.* contractors, subcontractors, consultants of a vast number of professions, suppliers, not seldom with responsibility for undertakings on site [Keijer,1992]. Further, the combination of actors varies from building project to building project. In view of what is said above, this puts special demand on the *shared structure of knowledge* pertaining to the construction process amongst all participants of the process. This knowledge should necessarily include also the overall goal of the enterprise. If there is a gap between the "official" goal and some other real but hidden goal of the project, which was discussed earlier, such a circumstance could severely frustrate the possibility to have a smooth information transfer for the process between the parties involved.

In order to circumvent these inconveniences different measures have been suggested. The contractual arrangement could influence heavily on the possibility to establish a substantial shared structure of knowledge for a given project. In this respect the *design-build* form seems much more favourable than, *e.g.*, the *lump*

*sum* contract. The Japanese construction industry, *e.g.*, seems to have adopted in practice the concept of *computer integrated construction* more easily than most of its Western competitors. This has been attributed to the domestic organisation of the construction industry in Japan where negotiated design-build contracts predominate, see [Bennett&al,1987]. In another study [Building Britain 2001, 1988] however, one foresees that the fragmentation of the building process, at least in Britain, will prevail: "successful organisations will be loosely structured networks of specialist teams, either formed into large companies or remaining as informal networks of separate firms" [ibid. p.26]. The latter is also more in line with recent arguments by other authors, *e.g.* [Hammer&Champy,1993] and [Naisbitt,1994].

## 2.4 NEED FOR STRUCTURED INFORMATION HIERARCHIES

The different aspects and the different requirements of an appropriate structure of the information transfer of the building process, which have been touched upon above, must be further analysed and organised. Some form of hierarchies must be developed in order to manage the vast amount of information which is generated, transferred and utilised at different stages of the the building process. The hierarchy is the most natural form of organisation [Koestler,1978,p.30]. Only in trivial cases, however, one hierarchy will suffice, in order to arrange all elements of given set. A number of such hierarchies have to be defined. The information-carrying elements will belong to one or several of these hierarchies. The task will be to define an appropriate set of such relevant hierarchies, so as to be able to address and handle desired procedures operating on the elements.

## 2.5 AXIOMATIC DESIGN

The hierarchy (or hierarchies) of pieces (elements) of information convenient for being transferred in the building process in the general sense elaborated above must be selected according to some governing principle. To maintain stability of overall requirements and solutions, when the process proceeds to more detailed and low-level problems of design and construction, is a primary objective of such a principle.

The principle of *axiomatic design* according to [Suh,1990], seems to offer a general approach to the matter under discussion. It should be noted that the word *design* should not be interpreted as engineering or structural design only, albeit the source of the concept has emerged from this field. Axiomatic design is based on two axioms (ibid. p.9), *i.e.*

*the independence axiom*, which prescribes independence of the the governing functional requirements on each successive level of the design procedure, and

*the information axiom*, which states that minimum required information, provided axiom 1 is fulfilled, yields the optimal solution.

Procedures similar to axiomatic design are very often practised by good designers more or less unconsciously. The interesting point here is that good practice can be based also on a consistent theory. Referring again to the structural steel design process, the observation made by Howard&al, [Howard&al,1992], concerning the representation of loadcases either as subclasses of classes of structural steel members or as a independent class hierarchy of loadcases, could, *e.g.*, very well be fully contained in a theory based on the two axioms quoted above.

The principles of axiomatic design will be further elaborated, see section 4.1.3.

### 3 MODELLING THE STRUCTURAL STEEL DESIGN & MANUFACTURING PROCESS

#### 3.1 GROUP DYNAMIC MODELLING

The discussion, so far, has dealt only with the rationale for a deep understanding of the building process, its driving forces, its constraints and its conditions in general. The treatment has not been specifically referred to the structural steel construction process, but is, of course, equally applicable to this, as a subprocess of the building process as a whole.

In order to pursue the investigation along the line outlined above a number of *group dynamic modelling sessions* have been carried out. This type of modelling sessions are frequently used at business modelling, very often as an introductory step of an information system development, *e.g.*, [Avison&Fitzgerald, 1988]. The aim of the modelling sessions is to arrive at a deep and common understanding within group what the elements of the business process in question really are, how are these elements related and what are their relative importance. The *current* business procedures are in focus; the aim is not to model a desired or prospective procedure. The number of participants in a session is limited to four to six persons, all experts of the field to be modelled, apart from one or two who act as monitors.

In the research project we have adopted a model for the group dynamic sessions developed and elaborated at the Swedish Institute for Systems Development [SISU-TRIAD,1993], a model which has been used extensively during several years for systems development in large Swedish corporations, like ABB, Ericsson, Skandia, Swedish Telecom and Volvo. Experience from modelling of processes with many independent actors, like the building process, is however lacking. The model is strong in its basic concepts, but informal and unrestricted at implementation for a particular case.

The work for a particular session starts with defining its scope, an agreement among the participants about how to work, and what the session aims at. The walls of the session room are covered by transparent plastic, on which the model gradually emerges during the work. Pieces of paper, on which important concepts, hints, observations are written are attached to the wall. The concepts, *etc.*, are connected by annotated lines ("depends on", "can cause", "governs", "inhibits",



etc.). A semantic network grows, schematically illustrated as in figure 5. The experts visualise their knowledge in the field, argue against each other, accommodate to each other. A session takes three to five hours, in general. The result is saved for subsequent analysis. It is obvious that the modelling sessions of their own cannot provide full information of the real process. The strength of the method is the co-operation element of it. The task of the monitor is to achieve a balanced session with active participants, without letting anybody dominate excessively.

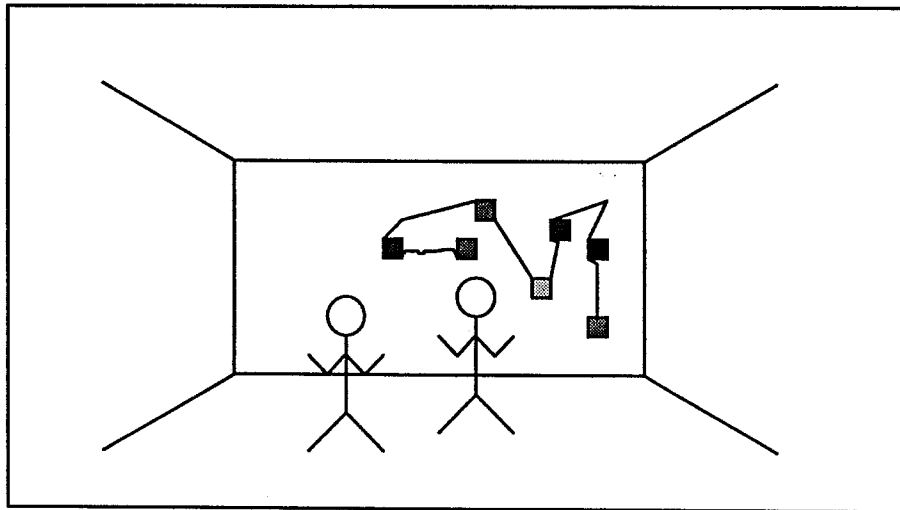

Figure 5. A concept modelling session schematically illustrated.

The TRIAD model is elaborated out of four different aspects of an enterprise or a process, i.e. the *objective/intention* aspect, the *acting/performance* aspect, the *resources* aspect, and the *rules* aspect. The relationship between the different aspects can be semantically interpreted, figure 6.

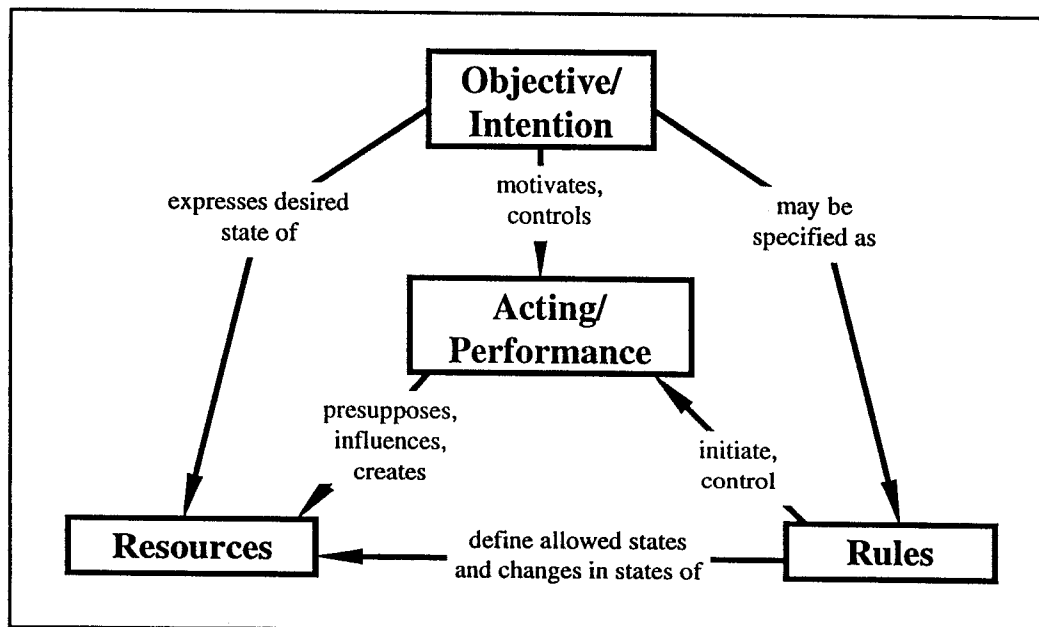

Figure 6. Four interlinked aspects of a complete description of a process. After [SISU-TRIAD, 1993].

In figure 7 the objective/intention aspect is further elaborated as a semantic network, which in a given case, *e.g.* for the structural steel, is instantiated in a free way.

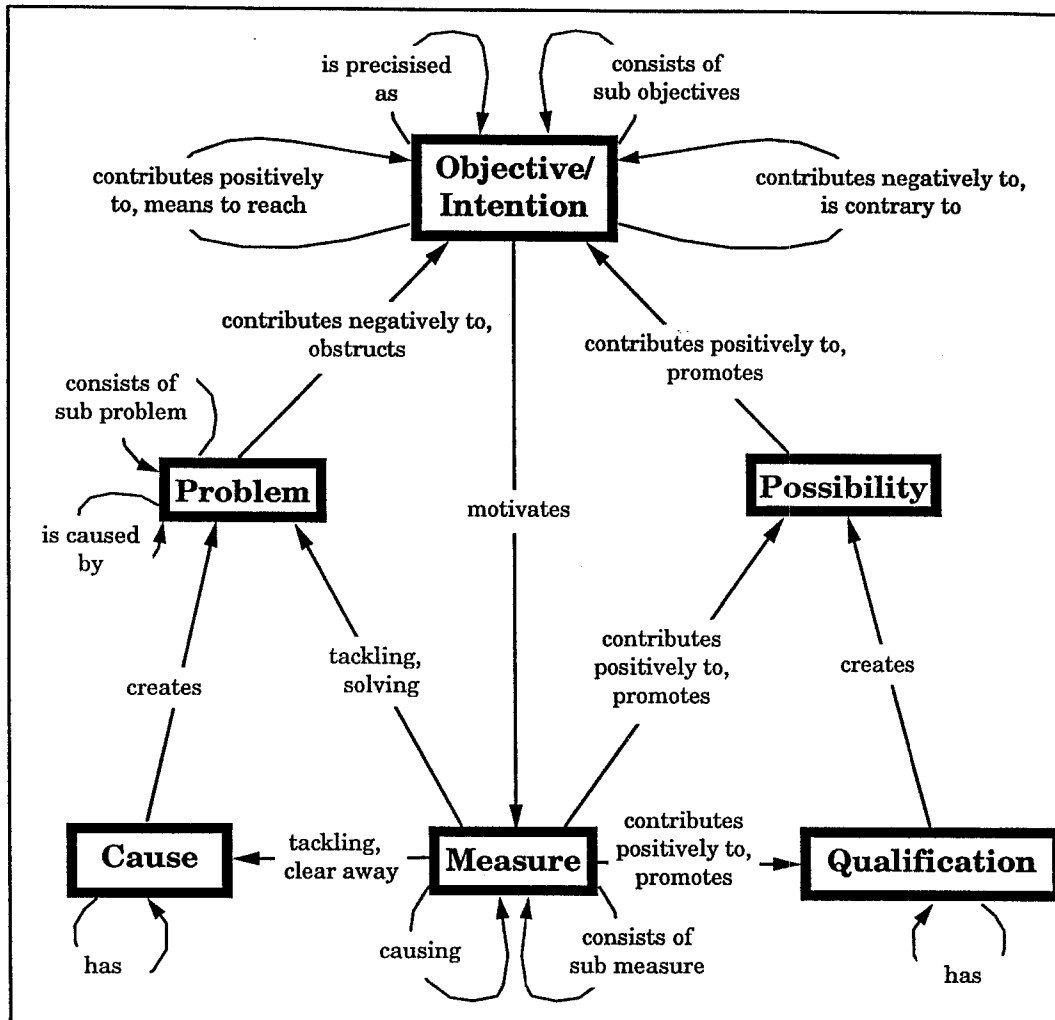

Figure 7. The objective/intention aspect expanded as a semantic network

Besides some minor exercises, four full modelling sessions were carried out, one regarding the goal/intention aspect and three the acting/performing aspect. The latter aspect was differentiated according to the expertise engaged for the different sessions, *i.e.* the early design stage, the manufacturing stage and the design/manufacturing interaction.

### 3.2 THE OBJECTIVE/INTENTION ASPECT

The first session, seminar 1 of total four, addressed the objective/intention aspect. This aspect encompasses more than a pure straight goal for the structural steel construction process. Goals and objectives lead the thinking into accountable and measurable quantities. Intentions goes further; also visions and aspirations should very well be included as meaning-carrying concepts in this part of the modelling.

A simplified depiction of the result of the seminar can be studied in figure 8A and 8B, which are two parts of a linked model.

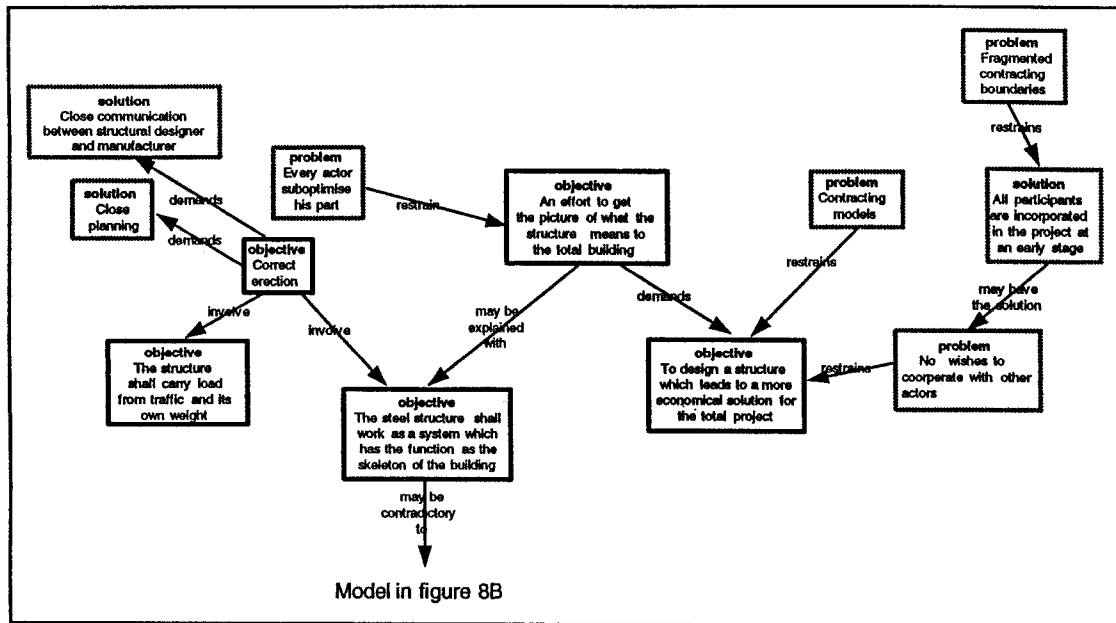

Figure 8A. Result from seminar 1 (part of)

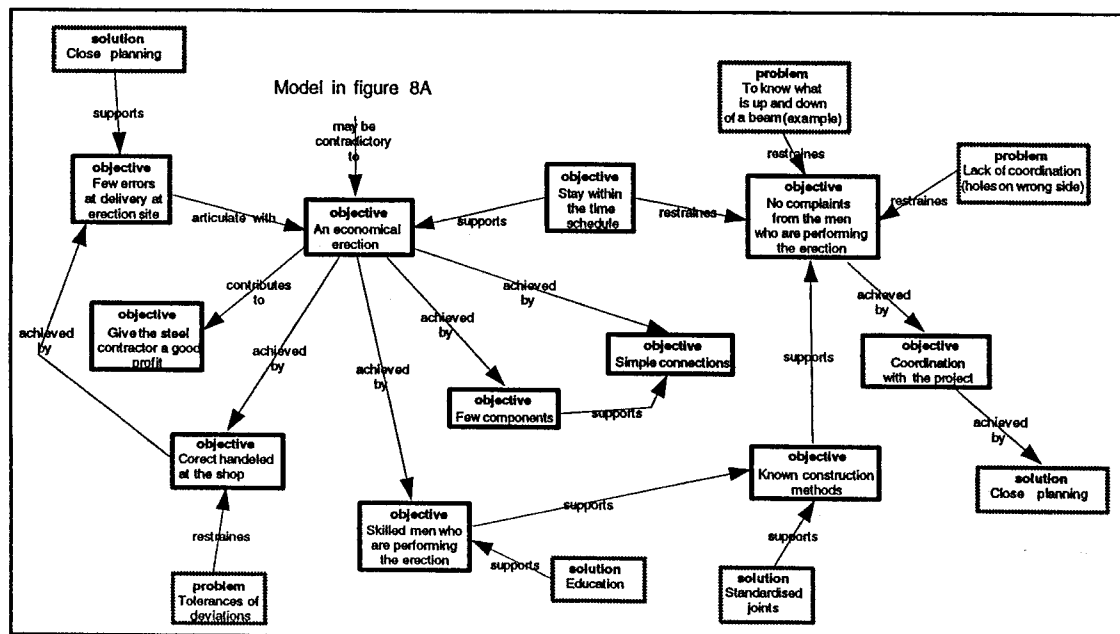

Figure 8B. Result from seminar 1 (part of)

The most striking result of seminar 1 is the almost complete subdivision of the aims and objective in two distinguishing spheres, which correspond to the two figures. If we start with figure 8B, this part of the resulting network concerns what generally could be denoted as the economic goal of the SSCP. *Low cost, fast completion, few claims* are the principle key-words.

Figure 8A on the other hand treats explicitly the *purpose* of the steel structure, *i.e.* how it physically and logically relates to other parts of the building and the process of its completion. The label of the coupling between the two parts of the same model was significant: "may be contradictory". Of course, no IT system really supporting the structural steel construction process could be based on an unresolved fundamental contradiction that concerns the principle objective of the process. The contradiction must be acknowledged and resolved, in one way or the other.

For further discussion of the arrangement of the seminars and their result is referred to [Sanne,1994].

### 3.3 THE ACTING/PERFORMANCE SEMINARS

Three acting/performance seminars were carried out. Each of the seminars covered a part of the steel construction process, that was studied in the entire project, *i.e.* the preliminary design, the manufacturing, and the design-manufacturing information transfer phase. Different participants took part in the different seminars, although some overlapping was arranged intentionally.

The seminars revealed many inconsistencies of the steel construction process. If the results are generalizable, it may, to some extent, explain the difficulties related to the specification of appropriate information structures for at least some parts of the building process, [Sanne,1994].

## 4 SIMPLE INFORMATION TRANSFER MODELS

### 4.1 THE BUILDING BLOCKS

The building blocks of a tentative preliminary information transfer model developed are based on three cornerstones. The first of these is a *model for information transfer* describing a sender and a receiver of a message according to what has been discussed above, see figure 4. The second pillar is the so called *triple role* concept developed by Juran [Juran,1988] for describing a process. The third is the *axiomatic design*, see section 2.4 above, which could be considered as a scientific approach to design [Suh,1990].

#### 4.1.1 Information transfer

One of the crucial task when transferring information between different processes is minimising the loss of information when translating the information into and interpreting it from the language of transfer. The problem may be described as the well-known problem of two people trying to transfer the contents of a picture from one's mind to that of the other without showing it explicitly. The problem lies in transferring the information in such way that the model of the picture does not lose information nor transform its meaning. There are two fundamental types of problems. At first, there is a necessity of a language that is well known for both

the sender and the receiver. Secondly, the language has to be as detailed and complete as possible, in order not to cause the meaning of the message to be fuzzed up.

#### 4.1.2 The triple role concept

Juran describes a process as a function consisting of an *input*, a *processor* and an *output* [Juran, 1988]. He further defines the output as a supplier for other processes. The input is defined as customer of the output of other processes. This leads to the definition of the '*triple role*' concept: every process consists of a supplier, a processor and a customer.

Burati&al [Burati&al,1992] have applied this concept to the construction process and describe the process according to figure 9. The figure shows that the construction industry may be described as a process and, as the methods are known to work for other processes, it may also be applied to the construction process.

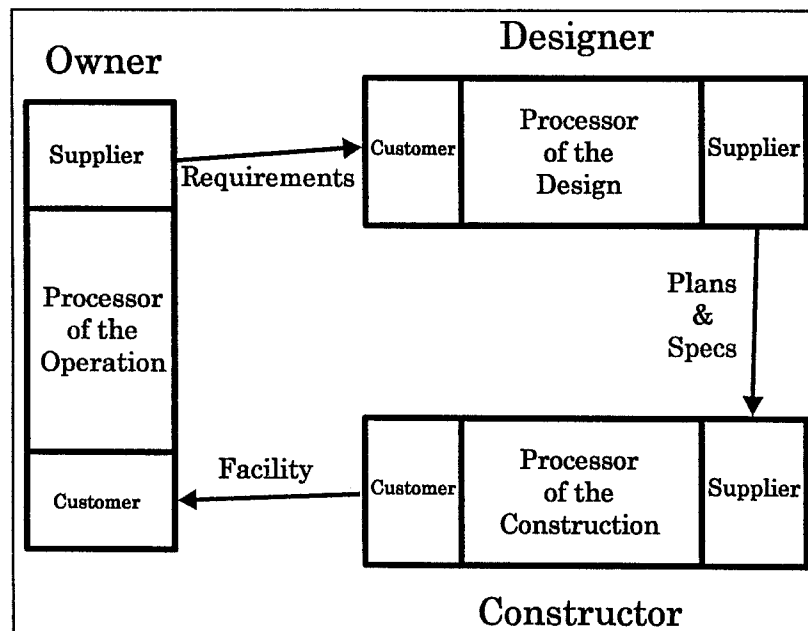

Figure 9 Three parties of the construction industry connected to a process. Juran's Triple Role Concept applied to the construction process, after [Burati& al,1992].

#### 4.1.3 Axiomatic design

The axiomatic approach to design is a systematic method for guiding the design process and analysing the result of it, [Suh,1990], [Hillström,1994]. The axiomatic approach consists of four key concepts and two axioms. The concepts are the following.

1. The design world consists of four distinct domains, *i.e.* the *consumer*, the *functional*, the *physical*, and the *process domains*, see figure 10.

2. The design process involves *mapping* between the domains.
3. In each domain, the design is represented by a characteristic vector of attributes which can be decomposed by *zigzagging* between the domains.
4. The mapping process involves *creative conceptualisation* which must satisfy the *design axioms*.

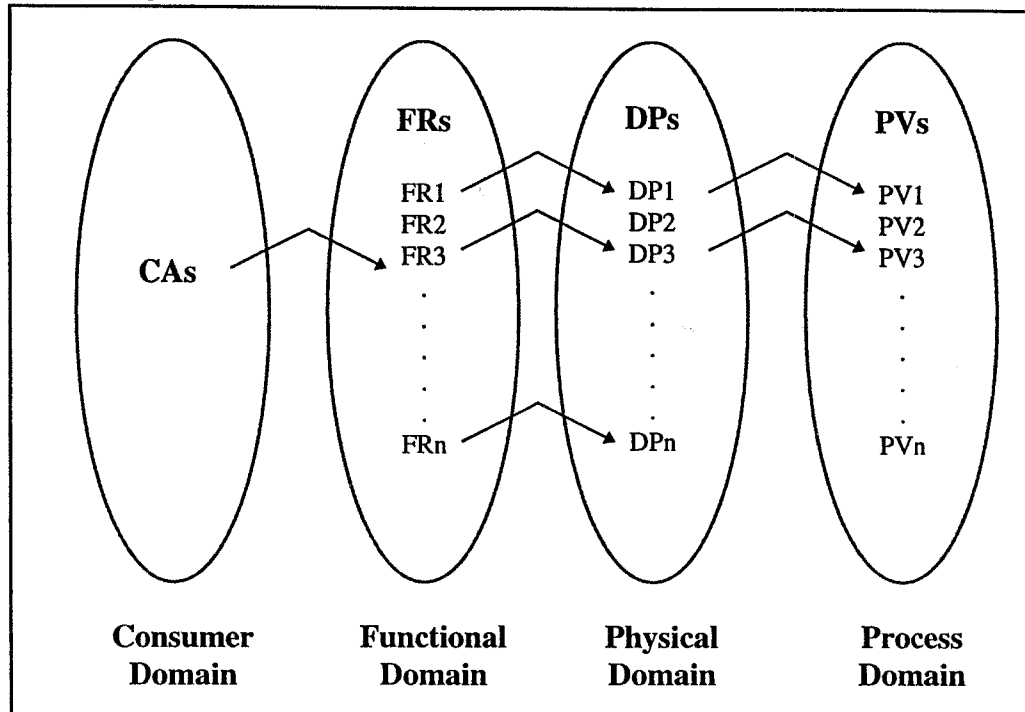

Figure 10. The four domains of the design world according to Suh [Suh, 1990].

The axioms may be stated as follows, see also section 2.4.

- Axiom 1** (the independence axiom). In an acceptable design, the mapping between the *functional requirements (FRs)* and the *design parameters (DPs)* is such that each *FR* can be satisfied without affecting any other *FR*.
- Axiom 2** (the information axiom). Among all proposed solutions that satisfy the independence axiom, the best design has the *minimum* information content.

The process of design is performed in a way so that the *consumer's desire* is defined in the consumer domain as *attributes*. These attributes are mapped into *FRs* in the functional domain. Each *FR* is then mapped into *DPs* in the physical domain.

The process proceeds. The design parameters so defined are starting points for establishing new *FRs* on next level. The *DPs* are further mapped in a similar way to the process variables. The design process proceeds as long as unresolved functional requirements exist on any level, see also figure 11.

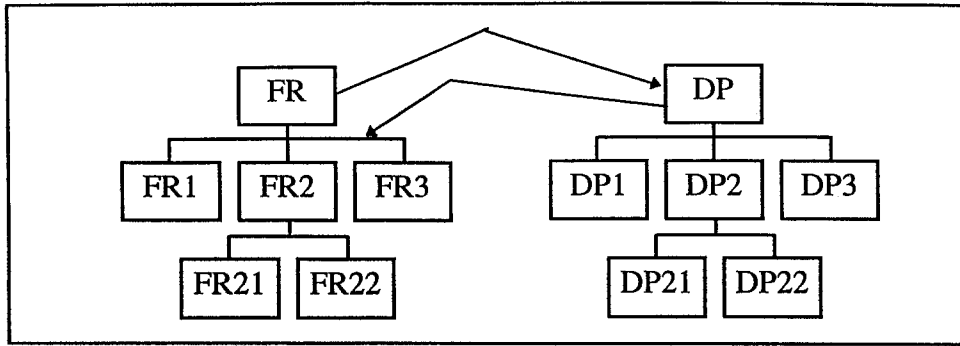

Figure 11 The zigzagging between the functional domain and the physical domain. Each functional requirement is mapped into the physical domain as design parameters. Design parameters are mapped back into the functional domain as new functional requirements on next level, after [Hillström, 1994].

The independence axiom defined above requires that the chosen *DPs* satisfy the *FRs* in such a way that the independence of the *FRs* always is maintained. The *FRs* and the *DPs* may be expressed as vectors of independent *FRs* and *DPs*. The relationship may then be expressed as

$$\{FR\} = [A]\{DP\}, \quad (1)$$

where  $\{FR\}$  is a vector of the functional requirements,  
 $\{DP\}$  is a vector of the design parameters  
and  $[A]$  is the design matrix.

Equation (1) is often referred to as the *design equation*. The left hand side of the equation represents “*what we want in terms of design*” and the right hand side represents “*how we hope to satisfy the FRs*”.

## 4.2 A GENERAL MODEL

### 4.2.1 Basic components

Based on the ‘*triple role*’ concept the information transfer process model can be described as divided into three stages, *i.e.* the *interpretation stage*, the *value-adding stage* and the *presentation stage*. The phases in the ‘*triple role*’ concept can be translated into the information transfer model as

customer	->>	interpretation stage
processor	->>	value-adding stage
supplier	->>	presentation stage.

The information is limited in the interpretation and the presentation while it is generated, altered and refined in the value-adding stage.

The information transfer in the structural steel construction process, SSCP, has been modelled according to these basic principles. A simple process model, where the information is transferred with drawings and specifications, has been established. The information available at the interpretation stage is based on drawings and specifications. The output, the activity at the presentation stage is equally confined to drawings and other specifications. The value-adding stage is then the single part of the process where the design of the steel structure takes place, see figure 12.

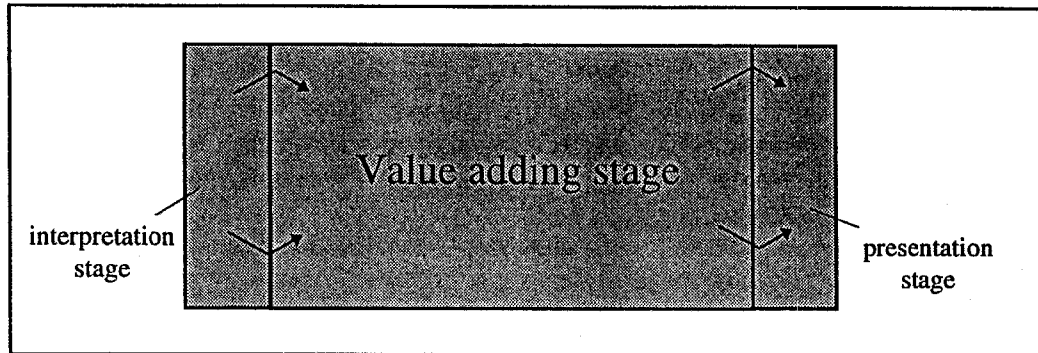

Figure 12 A basic model of a process with an interpretation stage, a value-adding stage and a presentation stage.

Each actor of a compound process could then be regarded as acting according to this basic model. The information transfer between the actors will then take place at the transition from the presentation of the results of one actor to the interpretation of available information by the next actor.

#### 4.2.2 Components of the information

The information available or generated in the process could be classified in three distinguishing categories, *i.e. desires (or needs), requirements, and solutions*. The information identified as a piece of *desire* causes a specification of requirement and the *requirement* generates a *solution*, *c.f.* the axiomatic design section, 4.1.3. We have

Desire ->> Requirement ->> Solution

The desires (needs) are specified at an early stage of a building project by analysing the desire for a building and its functions. This causes the architect to specify requirements which are translated into solutions by the architect and other actors in the design process. The requirements may be formulated as functions. In other words, the information of desires specifies *why* to build something, the requirement information specifies *what* is to be built, and the solutions defines *how* to build it.



### 4.2.3 Technical Solutions and Functional Requirements

For the further development of the general model it is assumed that the information managed in a process is of two types; *i.e.* *technical solutions*, *TS*, and *functional requirements*, *FR*. The *FRs* define the requirements for the product to be designed. The *TSes* are the solutions. There is only one final *TS* corresponding to each *FR*, although there might have been several possibilities from the beginning. The idea is that the information presented as a result should always be able to be separated into *FRs* and *TSes*, see figure 13.

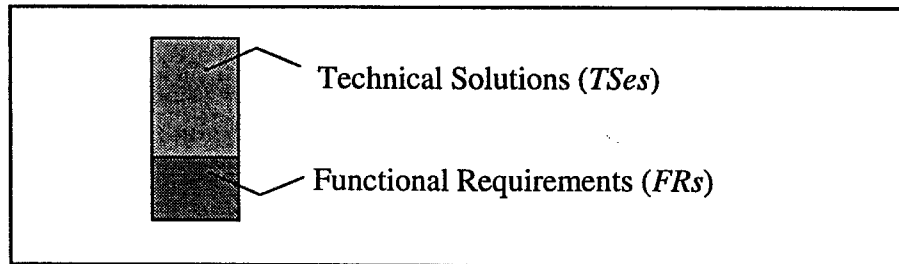

Figure 13 The information at the interpretation and the presentation stages is either of two types: requirements, *FR*, or solutions, *TS*.

In figure 14 the basic model for a single actor of the process is shown.

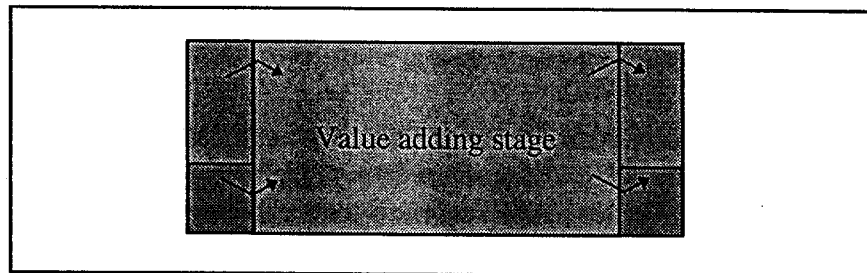

Figure 14 *TSes* and *FRs* from the interpretation stage are processed in the value adding part of a process. *TSs* and *FRs* are presented in the presentation stage.

### 4.2.4 Information transfer between a series of basic models

In a process like the current steel design&manufacturing process of a building project the information transferred is of the *TS* type, almost exclusively. Practically, no information transferred is of the type *desire*, *DN*, and only a minor part of it is of the type *FR*, in general.

In the further analysis it is assumed, however, that information transferred as *TS* partly will be interpreted as *TSes*, partly as new *FRs*. The functional requirements, *FR*, on the other hand will always be interpreted as *FRs*, see figure 15.

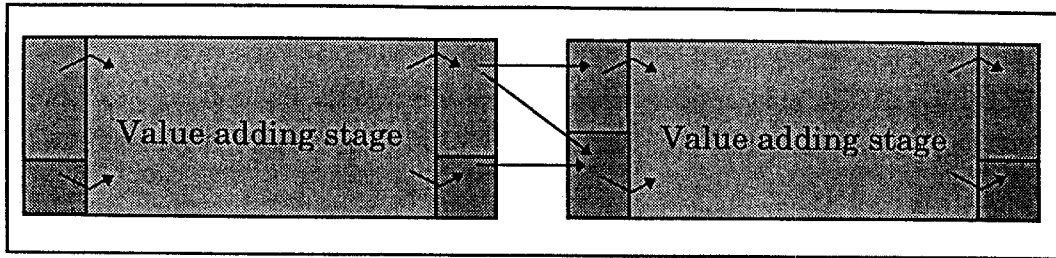

Figure 15 Information transfer between two processes. A TS is interpreted as FRs and TSeS. FRs are interpreted as FRs.

A simulation model based on the components of the earlier described SSCP has been developed and implemented in a computer programme. The starting FRs are successively transformed in the different subprocesses into solutions and new requirements. The quality of presentations, the skill of actors in the interpretation and the value-adding stages can be prescribed. The tasks to be performed can also be defined in different grades.

A number of preliminary test runs have been carried out. The results of these seem well in accordance with what could be expected with reasonable input data. The degrees of freedom, however, are large also in small test cases. With small alterations of the input significant changes are noted for the results. What is needed is input data from practice in order to successively develop the model and make it reliable. Sanne [Sanne, 1994] explains the model more in detail and presents results from some typical simulations.

It could be noted already, however, that if a certain technical solution is transferred, without a direct link to the correspondent functional requirement, very important information will be lost. As shown in figure 16 technical solutions are transformed into new functional requirements according to the principles of axiomatic design. These functional requirements are subsequent functional requirements to the one that caused the governing technical solution. Without knowledge of the original functional requirement, or - for that sake, which is an alternative, an absolute true fulfilment of the first axiom of axiomatic design given above - the subsequent functional requirement may be difficult to attain.

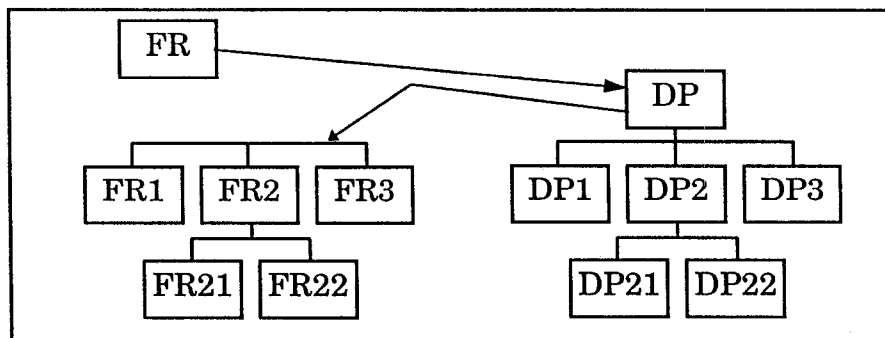

Figure 16 When the information about FRs are lost in information transfer the sub FRs, which are produced using the TSs, may be irrelevant to the previous FRs and to the overall desire.

## 5 CONCLUSIONS

The work is a part of ongoing research on "The Building process Seen as a Complex System". In order to be able to develop appropriate IT support systems for a complex building process, the understanding of the process, its components, relationships and driving forces, is indispensable. This work aims at contributing to such an understanding. The work is in this stage basically explorative, where a number of possible views of the basics of the structural steel construction process have been examined.

The experiences of group dynamic modelling are good. The preparation of the seminars should, however, not be underestimated. The outcome of these seminars is very much dependent of thorough planning and monitoring. In order to achieve most valuable results the monitors should develop professional skill in the particular method applied, in the first place, through extensive experience.

The work is in progress. The proposed simulation model will be further refined for extensive experimentation. The concept of shared structure of knowledge will be developed and introduced. The principles of axiomatic design will be further elaborated, especially its applicability to structural design. The complexity approach to the building process, in particular its implication for the transfer of information from design to manufacturing and construction at site will be pursued.

## 6 ACKNOWLEDGEMENT

This work has been supported financially from The Development Fund of the Swedish Construction Industry, through SIAB AB, within the framework of the research programme Information Technology in Building and Property Management.

## 7 REFERENCES

- Avison D E, Fitzgerald G, 1988, *Information Systems Development - Methodologies, Techniques and Tools*. 401 pp, Blackwell Scientific Publications, Oxford.
- Bennett J, Flanagan R, Norman G, 1987, *Japanese Construction Industry*. 83 pp, Centre for Strategic Studies in Construction, University of Reading, Reading.
- Building Britain 2001*, 1988. 82 pp, Centre for Strategic Studies in Construction, University of Reading, Reading
- Burati Jr J L., Matthews M F, Kalidindi S N, *Quality Management Organizations and Techniques*, Journal of Construction Engineering and Management, Vol 118, No 1, March 1992, pp 112-128.
- Checkland P, 1986, *Systems Thinking - Systems Practice*. 330 pp, John Wiley, Chichester.
- Freedman D H, 1992, *Is Management Still a Science*. Harvard Business Review, Nov-Dec 1992, pp 26-38

- Hammer M & Champy J, 1993, *Reengineering the Corporation*. 223 pp, Harper Business, N.Y.
- Howard C, Abdalla J A & Phan D H D, 1991, *A Primitive-Composite Approach for Structural Data Modelling*. Technical Report, No. 52, Center for Integrated Facility Engineering (CIFE), Stanford Univ., Palo Alto, CA. ISO/TC 59, 1993.
- Juran J W., 1988, *Juran on Planning for quality*, pp 341, The Free Press, N.Y.
- Keijer U, 1992, *Future Organisation of the Building Process*. Swedish National Report to the CIB W82 Symposium *Construction Beyond 2000*, June 15-18, Espoo, Finland. 100 pp, Swedish Council for Building Research, Stockholm.
- Keijer U, 1993, *Building Integrity: Classification beyond Building Parts and Spaces*. Proceedings of the First Conference on Management of Information Technology for Construction, Singapore, August 17-20. World Scientific & Global Publications Services, pp 135-147.
- Koestler A, 1978, *Janus - a Summing up*. 340 pp, Huchington, London
- Naibitt J, 1994, *The Global Paradox*. 304 pp, William Morrow&Co., N.Y.
- Sanne L, 1994, *Information Transfere Analysis and Modelling of the Structural Steel Construction Process*, 110 pp, Licentiate Thesis, Dept. of Structural Engineering, Royal Institute of Technology, Stockholm (to be published)
- Senge P, 1993, *The Fifth Discipline - The Art & Practice of Learning Organisations*. 413 pp, Century Business, London.
- SISU-TRIAD, 1993, *Modelleringshandboken* (The Modelling Manual). In Swedish, 35 pp, Swedish Institute for Systems Development, SISU, Stockholm.
- Suh N P, 1990, *The Principles of Design*. 401 pp, Oxford University Press, N.Y.
- Sundsvik L, Höjer J, Mellander K, 1983, *Byggprocessen-Belysning av nya samverkansmönster och arbetsformer* (The Building process - Review of new patterns of cooperation and collaboration). In Swedish, Report T:20, 156 pp, Swedish Council for Building Research, Stockholm.
- Waldrop M M, 1992, *Complexity - The Emerging Science at the Edge of Order and Chaos*. 380 pp, Penguin Books, London.