

Modelling the Effects of Information Technology on Construction

R A CHANDANSINGH¹

CH J VOS²

ABSTRACT

Quantitative statements on effects of IT are needed desperately to manage IT in construction, but are hard to make. This paper describes an approach to model the effects of IT on construction, based on the work of Mowshowitz (1992a-c). This approach makes use of graph theory to build a formal model of the construction process which allows for investigation and quantification of the effects of IT on construction. The approach is presently being used to model the cost-effects of CAD systems in concrete construction.

Key Words

IT; production digraph; information commodity; CAD; value; concrete construction

INTRODUCTION

Scope

Future use of Information Technology (IT) in construction will be influenced by the level of "fit" between the supply of IT-possibilities and the demand for IT-possibilities from the construction point of view (Figure 1). On the supply side, various possibilities are provided through developments in information technology itself, construction-specific IT application, and specific IT application in specialized fields of construction. Developments in these three areas result in general infrastructural possibilities (eg, hardware, networks), in general software (eg, operating systems, general Computer Aided Design (CAD) systems), in construction-specific infrastructural possibilities (eg, communication protocols, productmodelling (Luiten & Tolman, 1991), and specific applications (eg, specific CAD systems (Vos, 1990, FEM-programmes).

¹ *Research Associate, and*

² *Professor, Delft University of Technology, Faculty of Civil Engineering, Dept. of Mechanics and Structures, Section for Concrete Structures, P.O. Box 5048, Stevinweg 1, 2600 GA Delft, The Netherlands.*



On the demand side, CAD systems may be needed to meet the requirements put on construction, now and in the future. Requirements originate from social demand for (concrete) structures, global mega-trends, and developments in construction organization, technology, market, and resources. To meet these requirements it is needed to improve the efficiency and effectiveness of construction processes, the quality of the product, the quality of labour, and the flexibility of construction. The process improvements needed could make it inevitable to consider the use of CAD systems in construction processes seriously (Chandansingh & Vos, 1991).

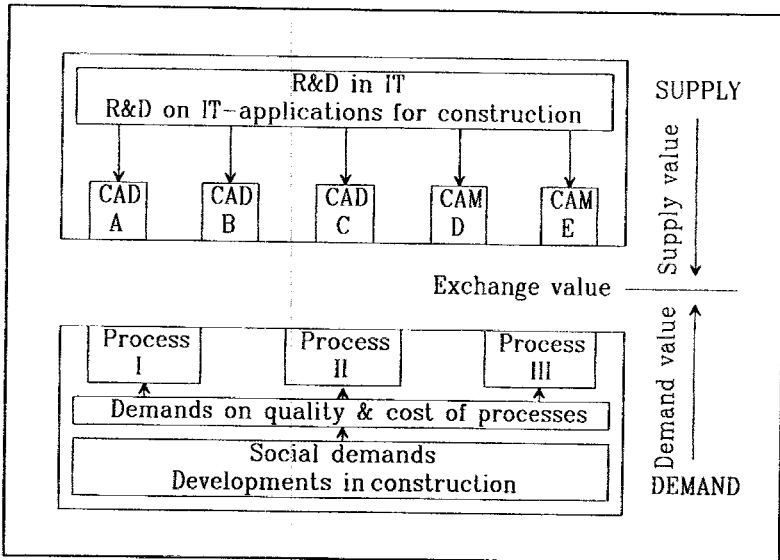

Figure 1. Demand and Supply of IT-tools for Construction

This research focuses on the various CAD systems available for use in Concrete Construction Processes (CCPs). By CAD systems is meant not only the software itself, but the infrastructure as well (eg, hardware, network), since it is considered to be an essential part of CAD systems; without the infrastructure CAD systems can not be used. These systems differ with respect to their capabilities, limitations, structure, and functions. Furthermore the systems are implemented and used in quite different intensities and varieties (Vos, 1990).

Although the use of CAD systems is still driven mainly from the supply side (technology push), more and more the demand side (technology pull) is considered when decisions concerning their use have to be made. The use of these systems induces costs in CCPs and results (or rather is expected to result) into benefits. The construction industry is striving more and more

towards a balance in costs (supply) and benefits (demand), instead of focusing on the most advanced CAD systems.

For "fitting" demand to supply the costs and benefits related to use of CAD systems must be determined. The information must be available to facilitate not only evaluations of current use of systems (ex-post evaluations), but predictive evaluations of the use of CAD systems presently under development and intended to be used in the future (ex-ante evaluations) as well. The evaluations, especially the latter, would be very useful for decisions concerning (investments in) the development of CAD systems.

In contrast with the costs related to the use of these systems, benefits are very hard to determine. The benefits (effects of use) of CAD systems have not been quantified well enough yet. Effects are specified mostly in qualitative terms and determined quantitatively only in specific situations. In the specific situations is measured the cost-reductions resulting from the use of one specific CAD system in one specific task. General conclusions can not be drawn, because the use of CAD systems in a task is viewed as a "black-box": the interaction between the task and the possibilities of systems are not identified explicitly. Furthermore, considering only one specific task provide a rather limited view on the benefits of CAD systems.

Aim of the Research

This research aims to model the effects of CAD systems, in order to determine the benefits (demand value) of the use of these systems in CCPs. CAD systems are seen as elements of production (of a certain kind), whose use affect performance in CCPs (Chandansingh & Vos, 1992). Modelling provides an analytical framework to investigate and measure effects, enabling quantitative statements on the value of CAD systems, through determination of an upperbound of their demand value. This upperbound reflects the maximum amount the user would be able or willing to pay for the use of these systems (Mowshowitz, 1992c). The research is restricted to cost-effects of CAD systems on production of reinforcement for concrete structures.

Relevance

This research will provide a descriptive and predictive model of the cost-effects of the use of CAD systems in CCPs. The model will provide practical management tools for the evaluation of the value of CAD systems in CCPs. These tools are needed by managers in concrete construction to assess the value of currently used systems, in order to check whether their investments pay-off. Of greater importance are the possibilities to assess the value of systems before they are introduced. This makes the model appropriate for supporting the strategic planning, development, implementation, and use of CAD systems. Decisions concerning the use, nonuse, and way of use of these

systems in CCPs are supported by the model.

Structure of the Paper

This paper describes the approach taken to model the cost-effects of CAD systems on Concrete Construction Processes. In the first place, the basic concept of "The market value of information commodities" (Mowshowitz, 1992a-c) is discussed. Secondly, the application of this concept for modelling cost-effects of CAD systems on concrete construction is elaborated on. Simplified examples are provided as well. Finally, preliminary conclusions, based on a first set of small cases are provided.

THE MODELLING APPROACH

The Market Value of Information Commodities

Mowshowitz (1992 a-c) introduced the concept of "The market value of information commodities". In this concept information is defined, viewing it as a property of production processes, as: "the ability of a goal seeking system to decide or control". "Decide" means choosing one alternative among several that may be executed in pursuit of a well defined objective. "Control" means ordering of actions that may be taken to achieve a well-defined objective. A "goal-seeking system" is one whose actions are designed to achieve a particular objective (Mowshowitz, 1992a).

Secondly, it is explained that the value of information is not a proper object of study, but the value of "information commodities". An information commodity is defined as: "a commodity whose function it is to enable the user to obtain information". Examples of information commodities are books, databases, computer programs, and advisory systems. The value of an information commodity derives from its capacity to furnish information. The capacity to inform depends on several aspects, termed Value Adding Dimensions (VADs), such as kernel, storage, processing, distribution and presentation (Mowshowitz, 1992a-b).

Thirdly, the concept of Production Digraphs (PDs) is introduced. Production Digraphs are formal structural models of production processes which allows for investigation and quantification of effects on production processes. PDs make use of graph theory and consist of nodes and arcs. Nodes represent tasks of the process being modelled, while arcs represent the several task-relationships; in this case cost-relationships. The effects of information commodities can be visualized through the changes they introduce in the PD. Changes can vary between "complex" structural changes in the composition of the graph, and "simple" changes in the weights of nodes and arcs.

Previous Applications

The concept of the market value of information commodities was successfully applied by Bellin (1991). He used the concept in his research on the effects of CASE (Computer Aided Software Engineering) tools on the software production process. He restricted his research to the cost-effects of these information commodities on the software production process.

Applicability of the Concept

CAD systems may have value for the construction process, which is a production process which can be modelled in production digraphs. If CAD systems are a type of information commodity, it should be possible to assess their value, by examining their effects on the costs of construction processes. To be considered an information commodity, CAD systems must meet the two requirements of an information commodity: appropriability and valuability (Mowshowitz, 1992a-b).

Each token (license) of a CAD system has a unique owner, who has purchased it. The same token can not be owned by any other owner, so a token of a system meets the requirement of appropriability. As CAD systems are traded and it is possible to determine both supply and demand value, the second requirement is met as well.

So, it can be concluded that CAD systems are information commodities (of a certain type), enabling modelling and assessment of their value in CCPs. The systems differ; they can be classified according to the VADs they possess. The value of CAD systems can be assessed through analyses of the effects of their VADs on production processes. These effects can be measured in terms of cost-savings and quality-improvements. This research is restricted to modelling cost-effects.

How to determine the demand value of CAD systems (as information commodities) in Concrete Construction Processes will be demonstrated in the next section. A tool to model and analyze effects of the use of CAD systems is described. Examples of the effects of different systems on production-costs will be provided, together with a brief description of the interaction between the systems and CCPs.

MODELLING COST-EFFECTS OF CAD SYSTEMS

Production Digraphs

The concept of Production Digraphs (Mowshowitz 1992c) will be used to analyze the cost-effects of CAD systems on Concrete Construction Processes. Production Digraphs (PDs) are formal structural models of production processes (Figure 2), representing a certain property of tasks and task-relations of a production process. In this case PDs are used to model the cost-

properties of CCPs. The production digraph methodology is used as a unifying descriptive tool, providing a framework for comparison and analysis of the costs of processes.

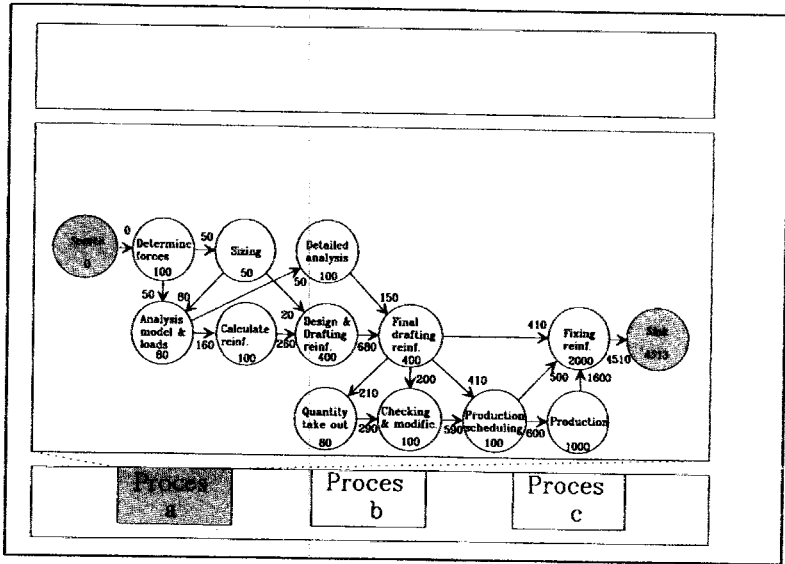

Figure 2. Production Diagram of Process I: "Realisation of Reinforcement in Concrete Slabs"

PDs are graphical representations, constructed out of nodes (representing relevant tasks) and arcs (representing task-relationships). Weights can be assigned to nodes and arcs to represent costs. Economic concepts and methods, such as Activity Based Costing (see review in Innes & Mitchell, 1991) facilitate the modelling of the cost-property of production processes in weighted PDs.

The type of change in the production digraph of the process is the dependent variable in the model. The type of CAD system that is introduced, and the type of process it is introduced in, are the two independent variables. The major assignment seems to be the determination of the relation between the several types of CAD systems and the several types of processes on one hand, and the specific types of changes in the production digraph on the other.

Concrete Construction Processes

PDs differ with respect to the specific CCPs they represent. PDs must be distinguished with respect to the type of concrete structure (eg, offshore platforms, bridges, fly-overs, buildings) and its structural concrete members

(eg, girders, slabs, columns). Furthermore differences occur with respect to the project-organization (eg, traditional, building-team, design and construct, turn-key), the knowledge and skills of people involved, the application of building codes, etc.

Recent analyses of CCPs, which are well-documented in reports (Blans & Toepoel, 1991; van Spanje & Toepoel, 1989; Toepoel, 1989), provide a sound basis for the construction of PDs. Tasks and task-relations are deduced from these analyses, which are represented as IDEF-0 (ICAM DEFINITION method) schema. This research can draw on several analyses performed in various Dutch projects, and projects done within the CADCRETE research-programme of the Delft University of Technology.

These recent process-analyses are used to construct PDs of CCPs and to classify CCPs, according to differences in their PDs. In the first place, the process-analyses are checked and modified through interviews with managers and employees in selected firms. Secondly, the cost-properties of tasks and relations are determined. Thirdly, differences in PDs are used to classify CCPs. Finally, the PDs are validated (and modified when needed), based on observations during execution of tasks of these processes in case-studies and during experiments at the participating firms.

The cost-effects of CAD systems are determined by constructing a new production digraph of the process and comparing it with the original. The new production digraph will be based on interviews, observations, case-studies, and experiments. Where possible, data will be extracted from literature as well.

In Figure 2, a production digraph of a (current) process (I) "Realisation of reinforcement in concrete slabs" is constructed, and is demonstrated here without extensive descriptions of the surrounding conditions. On a certain abstraction level all relevant tasks and task-relation of this process have been identified. The costs of tasks and task-relations are determined and represented by cost-weights. The costs-weights are expressed in Dutch guilders per ton (1000 kg) reinforcement; if necessary other weights can be used. It must be emphasized that another digraph is needed for another concrete construction process.

Value Adding Dimensions of CAD Systems

The effects of CAD systems depend on its Value Adding Dimensions (VADs), which coincides with the economic-term "values". Mowshowitz (1992b) distinguished five major VADs: kernel, storage, processing, distribution, and presentation. This frame of VADs is used as a starting point for the classification of CAD systems for CCPs. In this frame, current and future CAD systems are seen as a unique set of VADs. The set of VADs must be expanded to permit proper classification of these systems. The effects of the VADs on PDs are studied in depth. The effects of CAD systems are

determined as a combination of the effects of the separate VADs they consist of.

Table 1: Value Adding Dimensions of CAD Systems A and B

Value Adding Dimensions	CAD-system A	CAD system B
Kernel	Input aids for modelling of structural member Analysis of structural member Determination of critical moments and forces Calculation of required reinforcements Design of main reinforcement Determination of additional reinforcement Specification of reinforcement Generation of complementary data Checking of reinforcement Modification and manipulation of reinforcement Structuring of relevant project data Output aids	Input aids for modelling of reinforcement Generation of complementary data Checking of reinforcement Modification and manipulation of reinforcement Structuring of relevant project data Output aids
Storage	hard disk, type x	hard disk, type x
Processing	Kernel-routines in C C-compiler version y Operating system Dos 5.0 Pc 80486, 33 Mhz	Kernel-routines in Autolisp and C Autolisp-compiler version x, C-compiler version y Operating system Dos 5.0 Pc 80486, 33 Mhz
Distribution	Floppy, WUF-file format Hardcopy representations (drawings, etc)	Floppy, WUF-file format Hardcopy representations (drawings, etc)
Presenta-tion	Display features: On screen: several representations and views possible Hardcopies: plots of reinforcement drawings, schedules, etc. User interface: interactive, menu-driven	Display features: On screen: several representations and views possible Hardcopies: plots of reinforcement drawings, schedules, etc. User interface: interactive, menu-driven

VADs of CAD systems are identified partly from previous research performed in the CADCRETE research-programme of the Delft University of Technology (Blans & Toepoel, 1991; Vos, 1990). Furthermore knowledge on this issue, available at co-operating companies, involved in development and use of CAD systems, is used (de Jonge, 1992; Lebbink, 1991; van Spanje & Toepoel, 1989). This includes not only the software-houses, but consultants, contractors, and subcontractors as well, since a major part of developments are going on "in-house". As an example, the VADs of two different CAD systems are listed (Table 1).

Effects of CAD Systems on CCPs: Examples

The effects of CAD systems A and B on process I ("Realisation of reinforcement in concrete slabs") have been analyzed. The new PDs are displayed (Figures 3 and 4). The effects of system A and B are derivable from a comparison of the PDs represented in figures 3 and 4 (the new ones) and the production digraph represented in Figure 2 (the original). Furthermore, differences in the effects of CAD system A and B are derivable from a comparison of the PDs represented in Figures 3 and 4. These differences are due mainly to the differences in the kernel of the two CAD systems, as is illustrated in table 1.

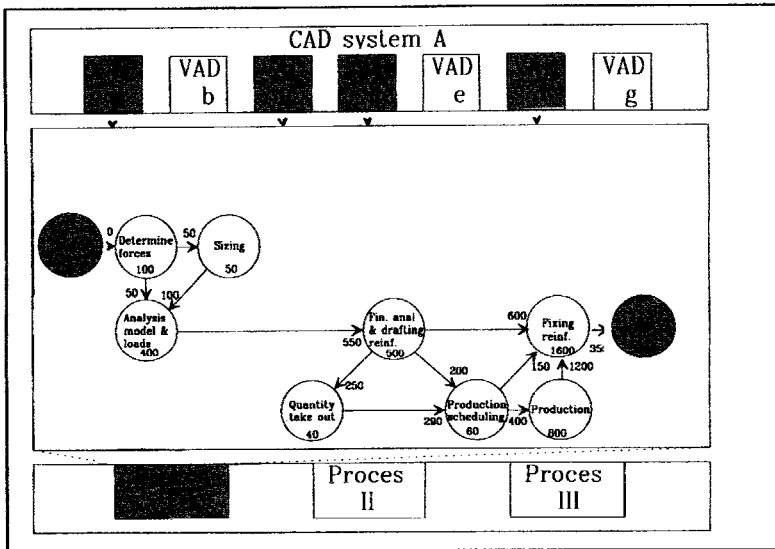

Figure 3. Effects of CAD System A on Process I: "Realisation of Reinforcement in Concrete Slabs"

The effects can be measured and expressed as the difference in the total costs of this process. The total costs is represented by the node-weight of the last node: the sink. From a comparison between Figure 2 and Figure 3 the effects of CAD system A are visible. The cost-effect of CAD system A is a reduction of $4510-3550 = 960$. In a similar way, comparing Figure 2 and Figure 4, it can be deduced that the cost-effect of CAD system B is a reduction of $4510-3470 = 1040$.

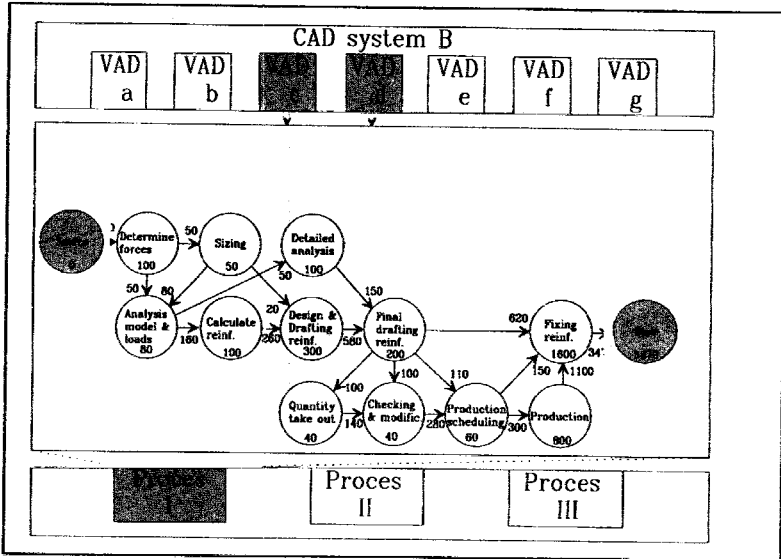

Figure 4. Effects of CAD System B on Process I: "Realisation of Reinforcement in Concrete Slabs"

There is another major difference in the effects of CAD system A and CAD system B: the structure of the resulting PDs are completely different. In general it is expected that a simple and unambiguous process results in a higher quality of the output, because there are less possibilities to make mistakes. This means that CAD system A could have a positive effect on the quality of the product. This can not be proven now, since quality of the product is not considered and modelled here.

The shown PDs and the considered CAD systems are simple ones, used her to demonstrate the modelling procedure. To determine the effects of CAD systems on concrete construction properly more detailed PDs are required. It is expected to classify CCPs in greater detail, according to difference in their PDs. Furthermore, a more detailed classification of CAD systems according to their VADs is needed.

CONCLUSIONS AND STATUS

Conclusions

The production digraph methodology seems useful for modelling the effects of CAD systems on Concrete Construction Processes. It provides good possibilities to visualize and quantify the effects of several systems on several CCPs. A classification of the systems according to their VADs and a classification of Concrete Construction Processes are needed for systematic analyses.

Considering CAD systems as information commodities provide a perfect opportunity to model their effects on production processes. The proposed framework for classification of CAD systems, according to their VADs, is a good start. However, an extension of this frame of VADs is needed to classify CAD systems in greater detail.

Systematic analyses of the effects of several CAD systems on several CCPs will result into identification of the general patterns in the relation between the VADs of CAD systems and their effects on Concrete Construction Processes. The predictive model will be based on these general patterns.

Status of the Project

A first group of cases have been modelled and analyzed successfully. It has been chosen to model and analyze the use of simple CAD systems on a simple concrete construction process. This has been done to gain some experience with the methodology and insight in the interaction of CAD systems and CCPs. Furthermore it provided possibilities to verify and modify the research methods and tools.

The interaction between the systems and processes will be studied more detailed and modelled in PDs. Interviews, observations and case-studies will provide the main empirical basis for a classification of CAD systems and modelling of their cost-effects on CCPs. Empirically, the model will be validated by experiments, concerning the use and non-use of CAD systems for the same set of tasks of CCPs. General patterns will be identified, resulting in a predictive model, which will facilitate systematic analysis of the effects of current and future use of CAD systems on CCPs.

References

Bellin, D (1991), *Information commodities and the production process: how the introduction of CASE tools affects the software development life cycle*; PhD Dissertation, The City University of New York.

Blans, B N and Toepoel, L (1991), CADCRETE(XV): CAD-KOLOM, voor berekenen, ontwerpen, en tekenen van kolomwapening; *Cement*, jaargang

43, nr 1.

Chandansingh, R A and Vos, Ch J (1991), IT-use in Reinforced Concrete Detailing: the current state, a forecasting-model, a future concept; In: *Proc. of the CIB-W78 Seminar "The Computer Integrated Future"*.

Chandansingh, R A and Vos, Ch J (1992), The value of information in the building process; an element of change? In: *Proc. of the CIB-W82 Seminar "Construction Beyond 2000"*.

Innes, J and Mitchell, F (1991), *Activity Based Costing: a review with case studies*; The Chartered Institute of Management Accountants.

Jonge, M F de (1992), Automation in the design and production phases of the Storebealt bridge; In: (Hogeslag AJ et al, eds) *Automation and Logistics in Precast Concrete*; Delft.

Lebbink, G A (1991), CADCRETE (XVII): CADKORF - Geautomatiseerde productie van wapeningstekeningen en wapening voor liggers van gewapend beton; *Cement*, jaargang 43, nr 6.

Luiten, G T and Tolman, F (1991), Project Information Integration for the Building and Construction Industries, In: *Proc. of CAPE 91*, Bordeaux

Mowshowitz, A (1992a), On the market value of information commodities: I. The nature of information and information commodities; *Journal of the American Society for Information Science*, Vol 43, No 3, (pp 225-232).

Mowshowitz, A (1992b), On the market value of information commodities: II. Supply price; *Journal of the American Society for Information Science*, Vol 43, No 3, (pp 233-241).

Mowshowitz, A (1992c), On the market value of information commodities: III. Demand price; *Journal of the American Society for Information Science*, Vol 43, No 3, (pp 242-248).

Spanje, W J E van and Toepoel, L (1989), CADCRETE(V): Tekenen van wapening met CAD/CAM; *Cement*, jaargang 41, nr 9 VNC.

Toepoel, L (1989), CADCRETE(VI): IOP - Onderzoek voor het wapeningsproces; *Cement*, jaargang 41, nr 10.

Vos, Ch J (1990), *CADCRETE; Progress in Concrete Research*; Annual report, Delft University of Technology, Volume 1.

c. 1993, *Management of Information Technology for Construction*, K. Mathur et al (Eds), World Scientific Publishing Co., Singapore.