

MATERIAL PRESENCE: SPATIAL POTENTIAL

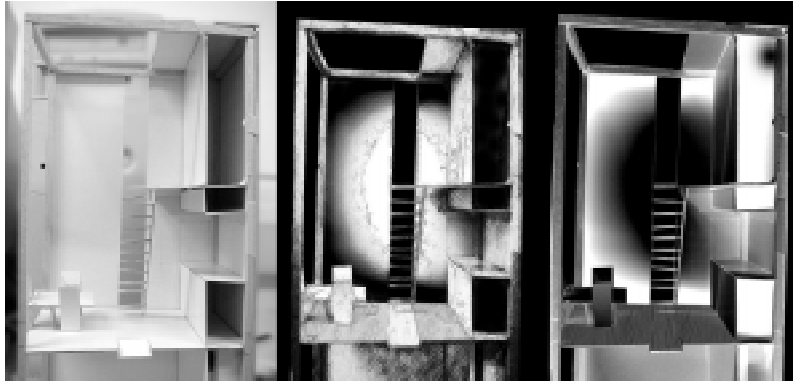

Tom Hughes BA (Hons) Dip Arch
School of the Built Environment,
University of Nottingham
Nottingham, U.K.
tom@2hd.co.uk

Guillermo Guzman Dumont
Facultad de Arquitectura Construcción
y Diseño
Universidad del Bio-Bio
Concepción Chile
gguzman@ubiobio.cl

Abstract

This paper describes two design studio projects with first year architecture students at the University of Nottingham.

Originally, this exercise was aimed to introduce them to CAD drawing tools, but due to some particular characteristics of the brief, some unexpected results came to add an interesting value to their design learning process.

From the exploration of a functional building typology through the digital construction of an iconic case study, it was developed a creative fabrication of absent architecture based on research, analysis and imagination. Then there was identified the most appropriate medium for communication of these defining characteristics.

Unexpected focus on material considerations over spatial analysis, motivated a second exercise which used image manipulation, based on graphic source material and digital imaging of physical models.

Development:

The first of these projects was a three-week course in the use of ArchiCAD. Assuming no previous knowledge of CAD, the primary aim of this project was to convey technical skills in the use of the software. As a first year course, the priority was to provide a useful tool for the students' further design projects in University, professional use of CAD being covered in later courses prior to graduation.

The objective of the project was for the students to produce an informative presentation on a functional building typology, through the modelling of an iconic exemplar in ArchiCAD. Working in groups of three, the students identified an exemplar through research into their chosen building typology. They then gathered information such as drawings, descriptions and images through research and, where possible, study visits (Fig 1, 2). In parallel with this initial research period, the students completed an exercise, which introduced them to

the basic tools in ArchiCAD through the modelling of a small two-storey house (Fig 3, 4)

The students then began to construct a digital model of their exemplar, working the analogue information gathered. This involved the translation of the available information into a useable form, often through re-drawing and sketch modelling in ArchiCAD (Fig 5, 6). The analogue information was explored and understood through the construction of the model, and missing information was identified. Undefined parts could be creatively reconstructed through the students' understanding of the typology and their digital exploration of the partially constructed space. In some cases the students decided to design their own exemplars, for example in the case of the nightclub typology, where insufficient source material was found to allow the reconstruction of an existing example (Fig 7).

Through an ongoing analysis of the analogue information and the emerging

digital data, the students attempted to identify the essential and defining architectural characteristics of their chosen typology and exemplar. This defined for them the illustrative material that would be required for the final presentation, and helped to focus their further CAD modelling efforts to these ends. Finally, the students produced a multi-media presentation of their typologies, including printed presentation boards to show 2D and 3D images, text and selected source material, and QuickTime VR and flythrough movies on disc (Figure 8).

The separation of this course from a studio design project ensured that time was devoted to the development of technical skills in CAD, and also helped to clearly define the objective of the modelling process. However, in isolating CAD teaching from design there is a danger that the skills developed may not be applicable in later projects. In terms of providing the students with a useful tool, this exercise could be said to be

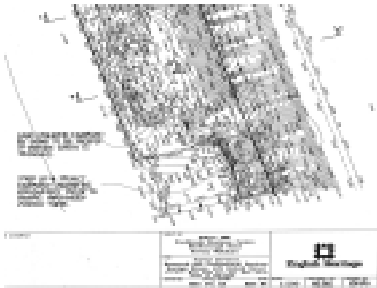

Fig 1: Source Information, survey drawings of fort

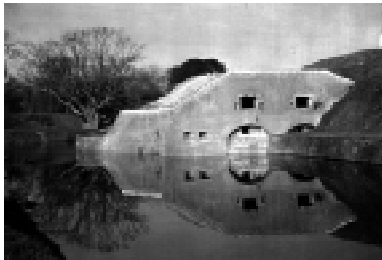

Fig 2: Source Information, site photos of fort

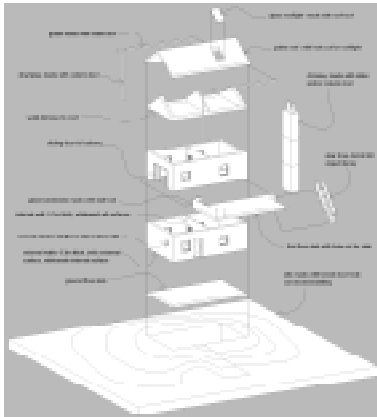

Fig 3: Initial exercise to learn archicad basic model tools



Fig 4: Typical outcome of initial modelling exercise

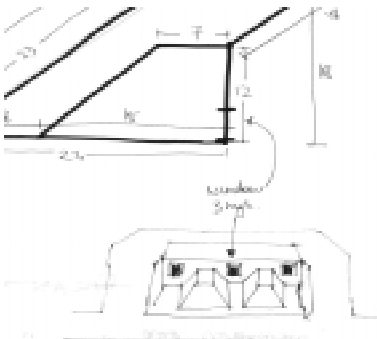

Fig 5: Interpretation of source information, Sketching

successful in the following ways:

- The integration of source material, and its interpretation through sketching and modelling has parallels in the exploration of initial design ideas. The students were encouraged to integrate CAD at an early stage, modelling incomplete information to test ideas (Fig 9). The early move into three-dimensional modelling will also help the students to avoid planimetric design solutions.

- The focussing of CAD modelling effort into production of useful information will be useful in deciding, for example, the level of detail required when modelling future projects (Fig 10, 11).

- The project was perhaps made less applicable to the students future design projects by the following factors:

- The recreation of an actual building limited the imagining and investigation of possibilities. The sense in which there was a 'correct' solution to the problem (i.e. the exact reproduction of the exemplar) limited the students' scope to experiment, play and accept chance outcomes in a way that might be useful in a design project (Fig 12).

- The extent to which the students explored the spatial potentials and the experiential nature of the spaces they were creating was limited. There was a great emphasis in the presented work on reproducing the materiality of the original building, its surfaces, detail and textures. There were a few examples of CAD modelling being used to convey an impression of the building beyond its physical reality (Fig 13, 14). The students who achieved this were able to demonstrate a more sophisticated understanding of the spatial potential and experiential nature of their buildings. If CAD is to be integrated to the design process at an early stage, techniques to produce more abstract material must be developed.

These limitations are to some extent a result of the task set for the students. The digital recreation of an existing building is a very different process to the exploration and presentation of architectural design ideas. However, some limitations may also be as a result of immersion into the ArchiCAD



Fig 7: Invented interior of Nightclub



Fig 8: Final presentation panel, nightclub typology

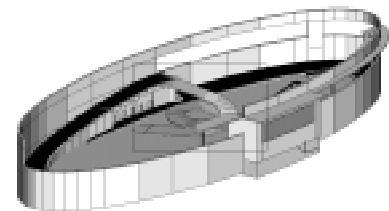

Fig 9: Early modelling to test spatial relationships and veracity of source data

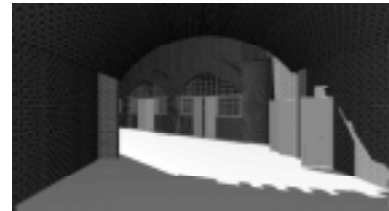

Fig 10: Level of detail in model, block model to convey overall massing

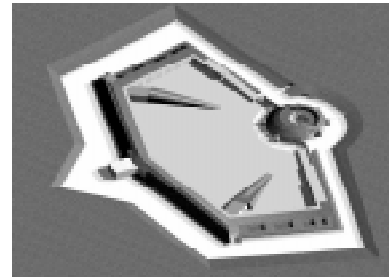

Fig 11: greater level of detail used where required to final presentation



Fig 12: a good reproduction of the chosen exemplar, which involved little investigation or experiment



Fig 13: experiments with light, material properties and colour allowed the students to investigate «atmosphere»



Fig 14: Experiential investigation of the penguin pool, a swimmer's eye view

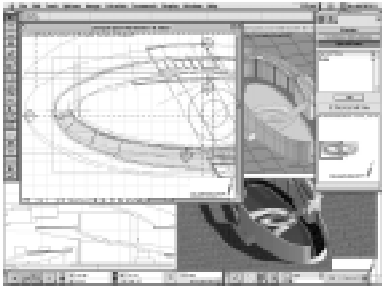

Fig 15: The archcad environment, links architectural drawing and realistic views

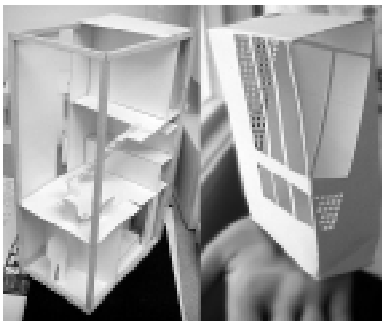

Fig 16: The original «life box» development models

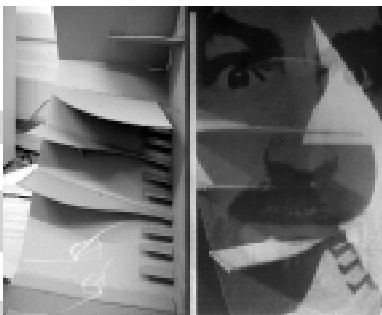

Fig 17: integrated process of combining inspiration and resulting shapes

environment, perhaps related to the precision of the 3D window views or the emphasis on producing photo realistic views in the rendering controls (Fig 15).

In the design process, exploration and experimentation can often be achieved by stepping away from precision, by changing media, changing scale or abstracting the information already produced. A second project for the same students sought to complement the exercise described above by introducing them to techniques for exploring spatial potentials through digital means.

Digital Workshop:

A one day digital workshop as part of a subsequent project was organised to let the students explore the spatial strengths of their designs through image manipulation, based on graphic source material and digital imaging of physical models.

The project was to design a Life box: a uni-personal space based in a standard box of 2x4x6 mts. Each student have to choose the character, the location and the position of the box in it's context, and generate a proposal for hosting the character's needs.

Initial stages of the design were referred to the location of this box in it's context, and cardboard modelling were an effective and fast way of development, but when the design goes to the interior of the box, there was a unexpected focus in just functional aspects, concentrating their design efforts in just furniture design.

Digital snapshots of their work models were used as a base of starting the digital workshop (fig 16), each of the students brought digitalised information about their characters, the site and other

relevant information, and started to explore overlapping images, filtering and editing "inspirational views" of their projects, through the use of Photoshop software.

Beyond the interesting and fast process of "testing" colours, materials and lighting into the different spaces of their projects, there's the fact of a very fruitful "design exploration" process, where the flat screen in front of them, transformed in a dynamic source of inspiration for discovering the spatial characteristics they wanted to produce in their designs; The concept of "Atmosphere" was mentioned in several times by them.

Although only in their first year of architectural studies, the students demonstrated an intuitive special aptitude for the translation process between analogue and digital information, generating a productive exploration and discovery of the spatial possibilities of their initial designs.

Conclusions:

Taken together, the two projects suggest a method for teaching CAD to first year architecture students that enhances technical skills and ensures that these are usefully applicable in subsequent studio design work.

An involved and intuitive spatial analysis of the modelled iconic case studies might engender a greater understanding of both their architectural reality and the inherent potential use of their functional and formal structures.

It might be useful in future to combine the two projects, encouraging students to move more seamlessly between CAD and image manipulation software, using both in the early project stages to investigate the potentials inherent in their emergent designs.



Fig 18: Sequence of stages of development, the original image, a material simulation with context, and finally a study of lighting.